

**VIDEO DISPLAY
TERMINAL**

VDT 52J

USER'S MANUAL

INTREPRINDEREA DE CALCULATOARE ELECTRONICE

ice felix
Data Processing Systems

**VIDEO DISPLAY
TERMINAL**

VDT 52J

USER'S MANUAL

INTREPRINDEREA DE CALCULATOARE ELECTRONICE

PREFACE

The VDT 52S Video Display Terminal is a fully featured general purpose ergonomic, conversational terminal, ideally suited for a wide range of application.

This Users Manual explains how to use the VDT 52S, and provides information on its installation and care. To help you effectively use the great variety of VDT 52S operating features, this manual emphasizes the various features and control codes.

I.C.E. FELIX constantly strives to maintain the accuracy and useability of our technical publications. We welcome your comments and suggestions, and have provided a pre-addressed post card at the back of this manual to note any changes you feel will improve this publication.

WARNING

This equipment generates, uses, and can radiate radio frequency energy and if not installed and used in accordance with the instruction manual, may cause interference to radio communications. Operation of this equipment in a residential area is likely to cause interference in which case the user at his own expense will be required to take whatever measures may be required to correct the interference. Only shielded cables with the shield terminated to the metal hood of the connector can be used.

VDT 52S IS A MULTIPLE PURPOSE VIDEO DISPLAY TERMINAL YOU CAN USE
IN A VARIETY OF ALPHANUMERIC AND GRAPHIC APPLICATIONS

HERE ARE THE 6 MODES YOU CAN OPERATE YOUR VDT 52S:

a) ALPHA mode - the terminal displays alphanumeric characters and performs alphanumeric editing in response to the information received from the computer. In this mode, VDT52S emulates the VT52 terminal functioning, including some additional features;

b) VECTOR mode - the terminal draws straight lines (vectors) on the screen in response to specific commands received from the computer, which identify vector endings. In this operating mode, the VDT52S terminal is fully compatible with TEKTRONIX 40xx series terminals, including additional features for scaling the X and Y coordinates. Thus, the terminal may be used for graphic applications written for different resolution terminals. The VDT52S terminal may also erase straight lines from the screen and may draw dashed lines, using a 16 points unidimensional pattern previously defined.

c) GIN mode (GRAPHIC INPUT) - the terminal enables interactive graphic information input, that is the user may specify a position in the 512x256 address space and send it to the computer in an encoded form. In this mode the compatibility with TEKTRONIX 40xx series terminals is also achieved.

d) MARKER mode - the terminal displays special predefined graphic symbols on the screen, at specific addresses received from the computer. The address encoding is the same as in the VECTOR mode.

e) BLOCK mode - the terminal fills or erases a rectangular area on the screen, identified by two opposite corners whose addresses are received from the computer. A 16x16 bidimensional pattern may also be used for rectangle filling. The address encoding is the same as in the VECTOR mode.

f) PAINT mode (optional) - the terminal performs the filling of the inside area of closed connexed contours on the screen. The filling process may be either unconditional or it may use a predefined bidimensional pattern consisting of 16x16 bits. An initial point (seed) must be provided inside the contour, whose address is encoded in the same way as in the VECTOR mode.

C O N T E N T S

| | | |
|-------|---------------------------------------------------------|----|
| 1. | GENERAL DESCRIPTION | 9 |
| 1.1 | Introduction | 9 |
| 1.2 | Operational description | 9 |
| 1.2.1 | Keyboard | 10 |
| 1.2.2 | Primary (Modem) and Auxiliary Port | 10 |
| 1.2.3 | Programmable Function Keys | 10 |
| 1.2.4 | Power Requirements | 10 |
| 1.3 | Specifications | 10 |
| 1.4 | VDT 52S Word Structure | 11 |
| 1.5 | International Keycap/Character Generator Sets | 11 |
| 2. | OPERATION | 15 |
| 2.1 | Keyboard | 15 |
| 2.3 | Commands | 19 |
| 3. | GRAPHIC OPERATING MODES | 35 |
| 3.1 | Graphic Coordinates Scaling | 36 |
| 3.2 | Graphic Attributes | 37 |
| 3.3 | Unidimensional and Bidimensional Patterns | 38 |
| 4. | VECTOR OPERATING MODE | 40 |
| 4.1 | Alpha Mode Selection | 42 |
| 4.2 | Current Graphic Position Transmission | 42 |
| 5. | BLOCK OPERATING MODE | 43 |
| 6. | MARKER OPERATING MODE | 45 |
| 6.1 | Marker Selection | 46 |
| 7. | PRINT OPERATING MODE | 48 |
| 8. | GIN OPERATING MODE (GRAPHIC INPUT) | 50 |
| 9. | INSTALLATION | 52 |
| 9.1 | Initial Preparation | 52 |
| 9.1.1 | Line Voltage | 52 |
| 9.1.2 | Set-Up Mode Preparation | 52 |
| 9.1.3 | Keyboard Plug-In | 52 |
| 9.1.4 | Monitor, Keyboard Adjustement | 54 |
| 9.2 | Interface Information | 54 |
| 9.2.1 | RS-232C Interface | 56 |
| 9.2.2 | Auxiliary Port Interface | 56 |
| 9.3 | Installing the VDT 52S | 56 |
| 9.4 | Power Turn-On | 56 |
| 9.5 | Screen Saver | 57 |
| 9.6 | Power Turn-Off | 57 |
| 9.7 | Care of the VDT 52S | 57 |
| 9.7.1 | Cleaning | 57 |
| 9.7.2 | Inspection | 57 |

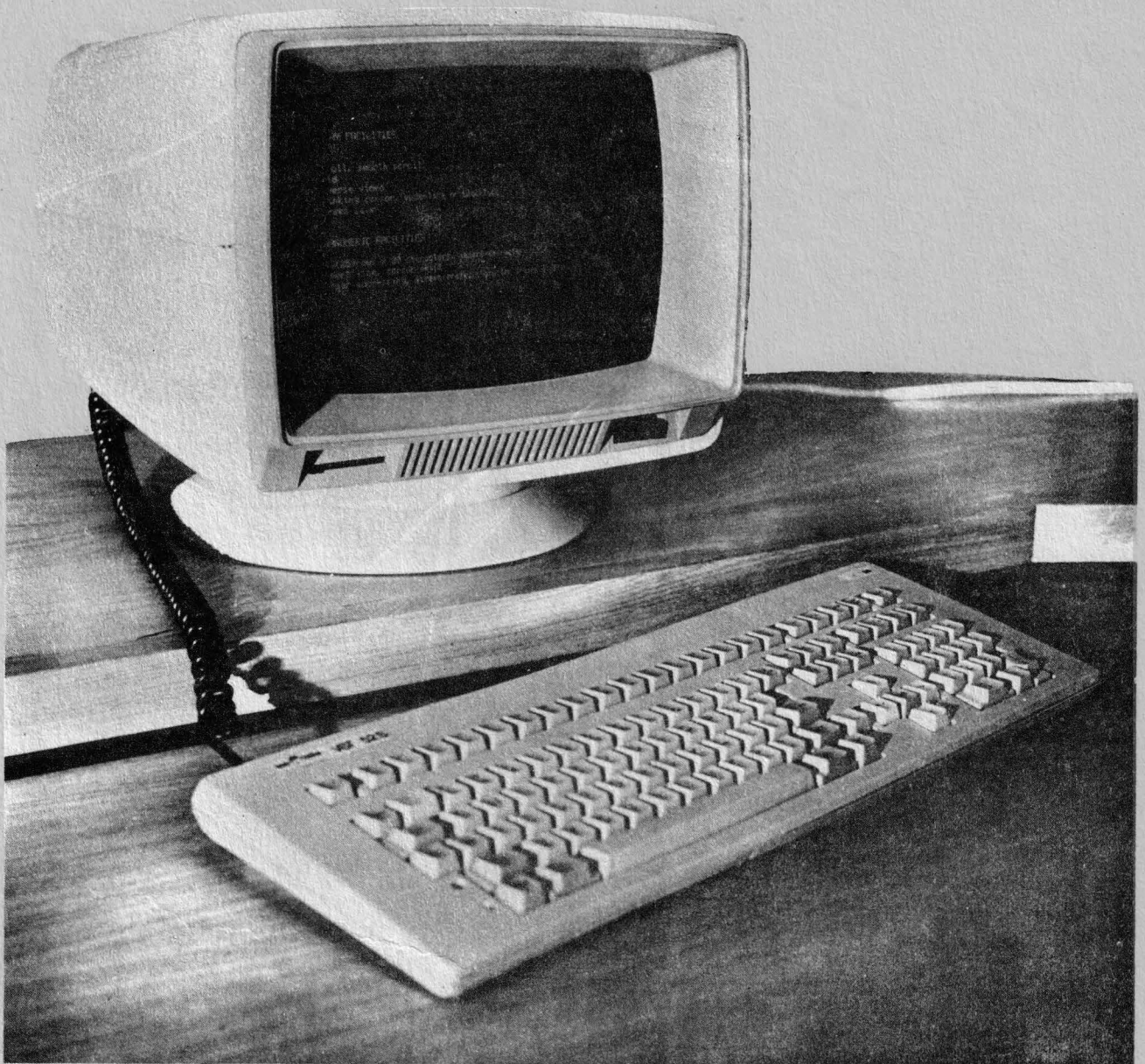

FIGURE 1-1. VDT 52S Video Display Terminal

SECTION I. GENERAL DESCRIPTION

1.1 INTRODUCTION

The VDT 52S Video Display Terminal, shown in Figure 1-1, is a smart, editing terminal designated for user convenience. It can be used in the Conversational mode of operation. Function keys can be programmed by the host or from the keyboard. The VDT 52S is also ergonomically designed for maximum user comfort. Its features include: a tilt and swivel monitor with positive detents; a low profile, user-friendly keyboard; a six feet long coiled keyboard cord. Designed for speed and versatility, the VDT 52S is ideal for most data terminal applications.

1.2 OPERATIONAL DESCRIPTION

The VDT 52S is used to enter, display, print, and send asynchronous data. It is also used to receive, print, and display data from an auxiliary device such as a host computer. Its most frequently used application is one in which an operator interacts in a two-way communication with a host computer. However, in some applications the data transfer may be unidirectional either from the VDT 52S to the host or from the host to the VDT 52S.

The VDT 52S is a complete stand alone data terminal consisting of a 12-inch (30.5 cm) CRT Monitor Unit and a detached, low-profile keyboard unit. Each unit is contained in a sturdy enclosure which also houses the required electronic circuits. Some features provided in the VDT 52S are:

- Full 128 ASCII character set.
- Four types of display memory configurations:
 1. 24 lines by 80 characters
 2. 24 lines by 85 characters
 3. 25 lines by 80 characters
 4. 25 lines by 85 characters
- Low profile keyboard with:
 - Numeric keypad with 14 keys
 - Five separate cursor control keys arranged in a cross pattern
 - 16 programmable function keys (shiftable to 32)
 - Cap lock key
 - Scroll screen key
 - User friendly layout
 - Tilt mechanism
- On-Line or local modes.
- 12-inch display with:
 - Vertical scrolling
 - Full screen reverse video
 - 5 x 8 character matrix

- 6 modes of operation:

1. Alphanumeric mode (VT52 compatible)
2. Vector mode - draws straight lines on screen (Tektronix 40xx compatible)
3. GIN (Graphic INput) mode (Tektronix 40xx compatible)
4. Marker mode (Tektronix 4100 compatible)
5. Block mode - lights on and off rectangular areas on screen
6. Paint mode (optional) - fills in a contour existing on the screen (with, eventually, a bidimensional pre-set pattern)

- Absolute cursor positioning

- Variable 7 or 8-bit data word structure

- Nine communication rates in full-duplex and half-duplex send/receive modes

- RS-232C modem interface and RS-232C auxiliary interface port

- Two print modes:

Alpha print
Graphic print

1.2.1 Keyboard

The keyboard, for operator comfort, is attached to the rear of the monitor with a 6-foot coiled cord to provide complete keyboard mobility.

1.2.2 Primary (Modem) and Auxiliary Ports

The VDT 52S comes standard with two ports: the RS-232C Modem Port and Auxiliary Port which are located at the back of the terminal. The Modem (I/O) Port is the link, or interface that handles the flow of data in both directions between the VDT 52S and the host computer.

The Auxiliary Port permits the use of a printer, such as CD 9335 when hard copy of data is needed.

1.2.3 Programmable Function Keys

The VDT 52S has sixteen programmable Function keys (shiftable to thirty-two).

1.2.4 Power Requirements

The VDT 52S can accept 220 VAC +/-10%, 50 Hz or 60 Hz.

1.3 SPECIFICATIONS

The VDT 52S specifications are listed in Table 1-1, page 12.

1.4 VDT 52S WORD STRUCTURE

The VDT 52S transmits serial asynchronous data in a 10 bit format in the sequence: one start bit, seven or eight data bits, one or no parity bit, and one stop bit. Parity selection (odd, even, or no parity) is permitted only with a seven bit data word. If an eight bit data word is selected, then bit eight can be designated to be either 1 or 0.

The received data shall be formatted the same as the transmit data.

1.5 INTERNATIONAL KEYCAP/CHARACTER GENERATOR SETS

Several character sets are optionally available with the VDT 52S, as well as the associated keycap sets. These include UKASCII, French, German, Swedish, Finnish, Danish, Norwegian, and Spanish.

TABLE 1-1. VDT 52S SPECIFICATIONS

| SPECIFICATION | DESCRIPTION |
|---------------------------|-----------------------------------------------------------------------------------------------------------------------------------------------------------------------------------------------------------------------------------------------|
| DISPLAY | |
| CRT Screen | 12-inch (30.5 cm) diagonal; green phosphor with non-glare surface. |
| Display Area | 8.25" W (21 cm) x 5.75" H (14.6 cm) |
| CRT Console | Tilt and swivel mechanism with positive detents. 360° swivel capability; tilt 5° forward to 15° back of vertical. Removable base. |
| Horizontal Refresh Rate | 15 kHz |
| Vertical Refresh Rate | 50 Hz or 60 Hz, depending on line frequency (factory set at time of order). |
| Display Formats | <ol style="list-style-type: none"> 1. 24 lines by 80 characters 2. 24 lines by 85 characters 3. 25 lines by 80 characters 4. 25 lines by 85 characters |
| Display Page Density | min. 24 x 80 = 1920 characters max. 25 x 85 = 2125 characters |
| Character Font: | |
| Character Field | 6 x 10 dot matrix |
| Character Matrix | 5 x 8 dot matrix with descenders |
| Cursor | 6 x 10 blinking block or underline |
| Character Sets | 128 displayable characters including control codes. Optional international character sets available. |
| Visual Attributes | Reverse video. |
| Cursor Movement | Relative and absolute addressing. |
| KEYBOARD FUNCTIONS | |
| Keyboard | Detached, low-profile, with 6-foot coiled cord. Sculptured keys, selectric type layout. Calculator format numeric keypad. Two tone keypads, by function, rib dividers to separate three major groupings of keys. 11° keyboard tilt mechanism. |
| Keyboard Layout | QWERTY-Typewriter pairing. Optional QWERTY-teletype pairing, QWERTZ and AZERTY. |

TABLE 1-1. VDT 52S SPECIFICATIONS (continued)

| SPECIFICATION | DESCRIPTION |
|------------------------------------|-------------------------------------------------------------------------------------------------------------------------------------------------------------------|
| KEYBOARD FUNCTIONS (cont'd) | |
| Numeric Keypad | 14 keys, 0 through 9, Enter, comma, period, and minus. 0 and Enter keys are double-size. |
| Cursor Control | Up, down, left, right, home arranged in a "cross" pattern. Return, Line Feed, New line, Backspace, Tab and Back Tab. |
| Function Keys | Sixteen programmable function keys, shiftable to thirty-two functions each transmitting up to a 63 character sequence with either local or host destination code. |
| Function Command Keys | Escape, Clear/Delete, Aux Port, Break, Cap Lock, Shift, Control and more. |
| Operator Convenience | Selectable Key-click for audible feedback. Full screen reverse video selectable cursor. |
| EDITING | |
| Edit Operation | Editing can be from the keyboard or host. Editing function includes clear screen, erase to end of line/page, insert character/line, and more. |
| TRANSMISSION MODES | |
| Conversation Mode | Interactive (character-by-character transmission, Full or Half Duplex operation). |
| Control Characters | Control characters may be transmitted to computer and/or entered on screen. |
| Interfaces | RS-232C. |
| COMMUNICATIONS | |
| Primary Port | RS-232C, serial asynchronous ASCII communications. |

TABLE 1-1. VDT 52S SPECIFICATIONS (continued)

| SPECIFICATION | DESCRIPTION |
|----------------------------------|------------------------------------------------------------------------------------------------------------------------------------------------------------------------------------|
| COMMUNICATIONS (cont'd) | |
| Auxiliary Port | RS-232C with alpha-print and graphic-print. |
| Data Rates | 150, 300, 600, 1200, 2400, 4800, 9600, 19200, and 38400 baud. |
| Word Structure | 1 start bit, 7 data bits, 1 parity bit (odd, even, mark space or none - selectable) and 1 stop bit. |
| Parity | Even, odd, or no parity. |
| Stop Bits | 1 stop bit. |
| Format | ASCII serial asynchronous communications. |
| Busy Indication | Primary (Modem) Port: Sends X-OFF (DC3), X-ON (DC1) or DTR to host on busy/ready condition of main port or auxiliary port. Auxiliary Port: Senses X-OFF, X-ON from printer. |
| Input Buffer | 200 bytes. |
| Handshaking | X-ON/X-OFF or, DTR (Pin 20) may be used to indicate the terminals Busy/Ready status or no handshaking. |
| GENERAL | |
| Operating Environment: | |
| Temperature | 5°C to 40°C (41°F to 104°F) |
| Humidity | 10% to 85% without condensation |
| Power Requirements (Factory set) | 220 VAC, +/- 10%, 50 Hz/60 Hz, 45 Watt |

SECTION II. OPERATION

2.1 KEYBOARD

Most of the keys from the keyboard allow the operator to introduce to computer the printable or control characters. These characters are codified according to the ISO 646/ASCII recommendations. Some keys transmit one single character, others transmit two characters when pressed only once. Other keys, SHIFT for instance, do not transmit characters when pressed, but, instead, they modify the codes transmitted by other keys. All the 128 codes in the ISO 646/ASCII standard can be generated.

The data input from the keyboard can be performed by simply pressing the control characters and/or the keyboard alphanumeric characters.

During the "on-line" operation the code of each key is immediately transmitted on the line. The pressed key must be released before pressing any other key. If, when releasing a key another one is already pressed, the code corresponding to the later one will be transmitted when releasing the former one. If when releasing a key one or more keys are already pressed, the code transmitted on line will correspond to one of the pressed keys, but it is not sure to which of them. Therefore, in order to ensure a correct functioning of the keyboard, the operator must not press more than two keys at a given moment.

The keys which change the keyboard operating mode are: the two SHIFT keys, CTRL key, and CAP LOCK key.

SHIFT

The SHIFT key selects, when pressing together with an alphabetic key, the corresponding capital letter; when pressing with the other keys, it selects the symbol placed in the upper side of the label.

CTRL

The CTRL key forces, when pressing together with a special character or alphabetic key, a control code among the existing 33 control characters.

CAP LOCK

The CAP LOCK (capital letters locking) triggers a flip-flop circuit. In the initial position the circuit allows to the alphabetic keys to generate both the small letters and capital letters codes (with SHIFT). After pressing the CAP LOCK key, the circuit shifts its state and makes the alphabetic keys generate the capital codes only, no matter the position of the SHIFT key. After pressing again the CAP LOCK key, the circuit comes to its initial state.

The keyboard has four operating modes:

- * Small letters mode, when the SHIFT or CAP LOCK keys are not actuated and the CAP LOCK circuit is in its initial state.
- * Capital letters mode, when the SHIFT and CTRL keys are not actuated and the CAP LOCK key has been actuated once, after connecting the power supply.
- * Shift mode, when any or both of the SHIFT keys are pressed and the CTRL key is not pressed; the position of the CAP LOCK circuit is of no importance.
- * Control mode, when CTRL key is pressed.

Table 2-1, page 17 shows the codes transmitted by the main groups keys in all the four modes. The hexadecimal base is used and the comand is given by the keys positioning on the keyboard.

BREAK

The BREAK key determines the forcing of the data transmission line in the zero logic state for a duration equal to about 300 milliseconds.

The BREAK function is usually used to force the interrupt of the data coming to the terminal. It is included for older pograms users, written to function under "Half duplex". The "Half duplex" has only one communication line between the computer and the terminal.

If the communication line is under the computer control, BREAK is the only way to force an interrupt. However because VDT 52S has both an input and an output line, normally the BREAK key is not used.

PAGE

This key causes local erasure of the screen. It does not send any code to the computer.

The SHIFT PAGE key homes the cursor in local mode, without sending anything to the computer.

PRINT

This key causes local alphanumeric copy of the screen to the CD 9335 printer. It does not send any code to the computer.

The SHIFT PRINT key causes local graphic copy of the screen into the CD 9335 printer, without sending anything to the computer.

FUNCTIONAL KEYS

The F1-F32 keys in the upper side of the keyboard may send several code sequences to the computer. Their use will be fully described in a subsequent chapter.

REP

This key does not transmit a code by itself. It is used together with other keys. Any key which transmit a code to the computer will repeatedly transmit the respective code if it is pressed while the REP key is also pressed. The functional keys which transmit a character sequence on each pressing, will repeatedly transmit this sequence if they are pressed together with REP. The repetition frequence is 10 Hz.

TABLE 2-1. THE CODES TRANSMITTED BY THE MAIN KEYBOARD

| Key | Mode | | | |
|----------|---------------|-----------------|-------|---------|
| | Small letters | Capital letters | Shift | Control |
| ESC | 1B | 1B | 1B | 1B |
| 1 | 31 | 31 | 21 | 31 |
| 2 | 32 | 32 | 22 | 32 |
| 3 | 33 | 33 | 23 | 33 |
| 4 | 34 | 34 | 24 | 34 |
| 5 | 35 | 35 | 25 | 35 |
| 6 | 36 | 36 | 26 | 36 |
| 7 | 37 | 37 | 27 | 37 |
| 8 | 38 | 38 | 28 | 38 |
| 9 | 39 | 39 | 29 | 39 |
| 0 | 30 | 30 | 30 | 30 |
| = | 5F | 5F | 7F | 1F |
| - | 2D | 2D | 3D | 2D |
| ~ | 5E | 5E | 7E | 1E |
| TAB | 09 | 09 | 09 | 09 |
| Q | 71 | 51 | 51 | 11 |
| W | 77 | 57 | 57 | 17 |
| E | 65 | 45 | 45 | 05 |
| R | 72 | 52 | 52 | 12 |
| T | 74 | 54 | 54 | 14 |
| Y | 79 | 59 | 59 | 19 |
| U | 75 | 55 | 55 | 15 |
| I | 69 | 49 | 49 | 09 |
| O | 6F | 4F | 4F | 0F |
| P | 70 | 50 | 50 | 10 |
| (| 5B | 5B | 7B | 1B |
|) | 5D | 5D | 7D | 1D |
| LF | 0A | 0A | 0A | 0A |
| DEL CHAR | 7F | 7F | 7F | 7F |
| A | 61 | 41 | 41 | 01 |
| S | 73 | 53 | 53 | 13 |
| D | 64 | 44 | 44 | 04 |
| F | 66 | 46 | 46 | 06 |
| G | 67 | 47 | 47 | 07 |
| H | 68 | 48 | 48 | 08 |
| J | 6A | 4A | 4A | 0A |
| K | 6B | 4B | 4B | 0B |
| L | 6C | 4C | 4C | 0C |
| ; | 3B | 3B | 2B | 3B |
| : | 3A | 3A | 2A | 3A |
| \ | 5C | 5C | 7C | 1C |
| @ | 40 | 40 | 60 | 00 |
| Z | 7A | 5A | 5A | 1A |
| X | 78 | 58 | 58 | 18 |
| C | 63 | 43 | 43 | 03 |
| V | 76 | 56 | 56 | 16 |
| B | 62 | 42 | 42 | 02 |
| N | 6E | 4E | 4E | 0E |
| M | 6D | 4D | 4D | 0D |
| ? | 2C | 2C | 3C | 2C |
| . | 2E | 2E | 3E | 2E |
| / | 2F | 2F | 3F | 2F |
| SPACE | 20 | 20 | 20 | 20 |

The Auxiliary Keypad

The VDT 52S's auxiliary keypad operates in one of two modes. Software can place the terminal in a mode in which the keypad can be used for data entry, just as the main keyboard's numeral keys can be used. If it is desired to distinguish between the typing of keys on the keypad and keys on the main keyboard, software can select a mode in which each key on the keypad transmits a unique Escape Sequence.

| Typing the key labeled... | IN NUMERIC KEYPAD MODE, transmits the following code(s) | IN ALTERNATE KEYPAD MODE, transmits the following code(s) |
|------------------------------|------------------------------------------------------------------|--------------------------------------------------------------------|
| 0 | 0 | ESC ? p |
| 1 | 1 | ESC ? q |
| 2 | 2 | ESC ? r |
| 3 | 3 | ESC ? s |
| 4 | 4 | ESC ? t |
| 5 | 5 | ESC ? u |
| 6 | 6 | ESC ? v |
| 7 | 7 | ESC ? w |
| 8 | 8 | ESC ? x |
| 9 | 9 | ESC ? y |
| . | . | ESC ? n |
| ENTER | CR | ESC ? M |
| (up arrow) | ESC A | ESC A |
| (down arrow) | ESC B | ESC B |
| (right arrow) | ESC C | ESC C |
| (left arrow) | ESC D | ESC D |
| (left blank key) | ESC P | ESC P |
| (center blank key) | ESC Q | ESC Q |
| (right blank key) | ESC R | ESC R |

If the keys transmitted by the "arrow" keys are echoed back to the terminal, they will cause the cursor to move one position in the direction the arrow points in.

The CONTROL, SHIFT, and CAP LOCK keys do not affect the codes transmitted by the keys on the auxiliary keypad, in either Keypad Mode.

SCROLL

This key is significant only with the terminal in HOLD-SCREEN Mode.

Unshifted, it directs the terminal to allow one scroll to occur, admitting one new line of data to the screen.

Shifted, it directs the terminal to allow 24 scrolls to occur, admitting one new screen of data to the screen.

GRAPHIC MOVEMENT KEYS

The four arrow keys and the 1,2,3,4,6,7,8,9 keys on the auxiliary keyboard have a special functioning: they cause graphic cursor movement during GIN (graphic input) operating mode. In the ALPHA mode they may be used for alpha cursor movement and as numeric keys, respectively.

2.2 COMMANDS

The previous section described how the keyboard can be used for transmitting characters to the computer. This section describes the reaction of the terminal when receiving different characters from the computer.

Displayable characters

The 20 up to 7E (hexadecimal) codes, which are codes for displayable characters in ISO 646/ASCII, can be considered as commands for displaying on the screen the characters they represent. When the terminal receives one of these codes, it will display the corresponding character on the screen, moving the cursor one column to the right.

If the cursor was in the last column of a line, will differentially react, function of the second configuration switch position:

- a) switch on : the cursor does not move, remaining thus on the character that has just been introduced on the screen. If the computer sends to the terminal another code for a displayable character, without explicitly moving the cursor by using one of the terminal commands, this new character will replace the old one.
- b) switch off: the cursor moves further to the first column of the next line on the screen. If the cursor was in the last column of the last line, a scroll-up line is lost, and a blank line appears in the last screen line. The cursor is positioned in the first column of this new introduced line. In this way, the characters sent by the computer will appear on the screen, from left to right and from upwards to downwards, even if the computer does not send commands for the cursor explicit movement at line beginning.

Control Characters

Some characters or character sequences are considered by the terminal as commands and are not displayed on the screen.

From the 128 ISO 646/ASCII code characters, 33 are considered to be control characters. That means that they do not represent characters that can be displayed on the screen. Some characters have been deliberately introduced in order to be used as commands. However, using only 33 codes, the terminal would quickly exhaust the available codes to represent the different instructions they perform. For this reason, one of the control code, called ESC (ESCAPE) has been reserved in order to declare that the next code, although it represents a character that could be displayed on the screen, must be interpreted as a command. For instance, if the terminal receives the 42 (hexa) code, it will display "B" on the screen. If it receives 1B, its ESC code, and then 42, it will not display "B" but, instead, it will perform a special command.

There are commands for cursor positioning, partial or total screen information erase, characters or lines elimination and writing on the screen, putting the terminal in other modes in which it reacts differently as well as for forcing the terminal to identify itself.

When receiving an ESC character, the VDT 52S terminal will interpret the next code as a command, instead of displaying it. This displayable code must appear next to ESC. It is called the final character of an ESCape sequence. If the final character is an invalid character, the terminal will run out from the ESCape, without acting.

Fillers

Some terminals cannot process characters and commands at the speed they come from the computer. These terminals require to the computer the transmission to the terminal of some characters without significance, named fillers; as a delay till the moment when the terminal is ready to process other data. The 00 (NUL) and 7F (DEL) control codes are most often used as fillers. Although VDT 52S uses another protocol for synchronization with the computer, it will ignore 00 code when it receives it (7F = DEL code provokes a special operation - the elimination of a character).

Cursor Moving Commands

1. Line Feed
invoked by LF (0A)

The cursor moves downwards with a character position in the same column next to the one in which it is.

If the cursor is initially in the last line, it remains where it was, but all the information on the screen scrolls one line up. The information that was on the first line is lost and on the last line a blank line appears. This process is called "scroll up".

2. Cursor down
invoked by ESC B (1B 42)

The cursor is moved downwards with a character position in the same column of the line next to the one in which it was.

If the cursor is initially in the last line, the "scroll up" does not occur. The new cursor position depends on switch 2: a) switch on - cursor does not move; b) switch off - cursor on the same column of the first line.

3. Regression line
invoked by ESC I (1B 49)

The cursor moves upwards with a character position on the same column of the previous line in which it was.

If it is initially in the first line, the cursor remains where it was, but all the screen information is moved downwards with one line. The information of the last line is lost, and a blank line appears on the first line. This process is called "scroll down".

4. Cursor up
invoked by ESC A (1B 41) or by SUB = CTRL/Z (1A)
(for VT52 terminal - only ESC A)

The cursor is moved upwards with a character position in the same column of the previous line where it was.

If the cursor is initially in the first line, the "scroll down" does not occur. The new cursor position depends on switch 2: a) switch on - cursor does not move; b) switch off - cursor moves on the same column of the last line.

5. Space
invoked by 20

The character in the cursor position is erased, and the cursor is moved one column to the right. If it is initially positioned in the last column, the cursor remains in the same place, or, it moves in the first column of the next line, function of the switch 2 position (on/off). If the cursor was positioned in the last column of the last line and the switch 2 is off, a "scroll up" occurs.

"Space" can be considered as a character erase command, or as a displayable character which replaced the original one.

The programs written for paper terminals, which position the carriage (or the cursor) by returning to head of line and then moves it to the right by spaces, must be rewritten because "space" erases data on VDT 52S. In order to move the cursor over already written data on the screen, the following command must be used.

6. Cursor to the right
invoked by ESC C (1B 43) or by NAK = CTRL/U (15H)
(for VT52 terminal - only ESC C)

The cursor is moved one column to the right. If it is initially positioned in the last column, the cursor remains in its place, or, it moves in the first column of the next line, function of switch 2 position (on/off). If the cursor has been positioned in the last column of the last line and the switch 2 is off, a "scroll up" occurs.

No character is erased on the screen if a scroll up does not occur.

7. Backspace or cursor to the left
invoked by BACKSPACE (08) or by ESC D (1B 44)

The cursor is moved one column to the left. If it is initially positioned in the first column, the cursor remains in its place or it moves in the last column of the previous line, function of switch 2 position (on/off). If the cursor has been positioned in the first column of the first line and switch 2 is off, a "scroll down" occurs.

8. Carriage return
invoked by CR (0D)

The cursor is moved at the beginning of the line in which it is positioned (the very left column). If it was already there, the cursor will not move. If the switch 4 (auto LF) is off, just after carriage return command has been performed, the line feed function will be performed.

9. Cursor Reset
invoked by ESC H (1B 48) or by EM = CTRL/Y (19)
(only ESC H for VT52 terminal)

The cursor is moved to its initial position the top left corner of the screen. If it has already been there, it stays where it was.

10. Tabulation
invoked by TAB (09)

The cursor is moved at least one column to the right and keeps moving to the right till it reaches a horizontal tabulation column. If one labels the column from 1 (left limit) to 80 (right limit), the horizontal tabulation columns are fixed on the following positions: 1, 9, 17, 33, 41, 49, 57, 65 and 73. If it has already been positioned on a tabulation column, the cursor moves in the next tabulation column.

If it has already been positioned in columns 73-79, the cursor moves one single position to the right. If it has already been positioned in the last column, the cursor remains in its position, respectively it moves in the first column of the next line, function of the switch 2 position (on/off). If the cursor has been positioned in the last column of the last line and the switch 2 is off, a "scroll up" occurs.

11. Cursor Absolute Positioning

invoked by ESC Y (1B 59) and by ESC 1 (1B 31)
(ESC Y only for VT52 terminal)

The next character after ESC Y sent by the computer to the terminal will not be displayed, but it will be considered as a screen line (column) indicator. The character received after that by the terminal will not be displayed, but it will be considered as a screen column (line) indicator. The cursor will move in the character position given by the pointed line and column. So, the commands of the cursor absolute positioning are as follow:

```
ESC Y #line #column
ESC 1 #column #line
```

and consists of 4 characters from the computer. In this 4 - character sequence, the control codes or other ESCape sequences must not be interfered. If that occurs, the obtained result is unpredictable.

For #line the computer sends code 20 (hexa) to indicate the screen top line, 21 to indicate the next line and so on. The code 37 (38) indicates the bottom line. The terminal will not vertically move the cursor, if it receives a #line out of the limits.

For #column, the computer sends code 20 (hexa) to indicate the screen left column and 6F (74) to indicate the right column. If the #column overpasses the limits, the cursor moves in the very right column.

Information Erase Commands

12. Character Erase

invoked by ESC S (1B 53) or by DEL (7F)
(this command does not exist at the VT52 terminal)

The character indicated by the cursor is erased. All the line characters situated at the right side of the cursor move in the next left position. At the right end of the line (column 80/85) a space appears. The cursor does not move at all.

13. Screen erase

invoked by ESC E (1B 45) or by CAN = CTRL/X (18)
(this operation does not exists at VT52 terminal)

All the screen information will be erased and the cursor will move in the top left character position.

14. Erase to End of Screen
invoked by ESC J (1B 4A) or by ETB = CTRL/W (17)
(ESC J only for VT52 terminal)

All the information from the cursor position up to the end of the screen will be erased.

If the cursor is positioned in the bottom right corner of the screen, only a character will be erased. If it is positioned in the top left corner, all the screen information will be erased.

15. Erase up to End of Line
invoked by ESC K (1B 4B) or by SYN = CTRL/V (16)
(ESC K only for VT52 Terminal)

All the information from the cursor position up to the end of line will be erased.

If the cursor is positioned in the very right column of a line, only the character indicated by the cursor will be erased. If it is positioned in the very left column of the line, all the line information will be erased.

Editing Commands

Screen editing commands are usually specific to the terminals functioning in the message mode. VDT 52S is not such a terminal. But the insertion/deletion line commands have been introduced among the terminal commands with another purpose than that one of editing a message processed by the operator for the computer. They can be used to achieve the information scroll on a screen zone that may include a variable number of lines from the bottom side of screen.

16. Character Insert
invoked by ESC R (1B 52) or by DC2 (12)
(this operation does not exist at VT52 Terminal).

All the line information positioned between the cursor and the right limit moves at the right with one position. The last line character is erased. In the cursor position a blank appears (this place may be then replaced by another character). In this case, the cursor does not move.

17. Line Insert
invoked by ESC L (1B 4C) or by ACK = CTRL/F (06)
(this command does not exist at VT52 Terminal)

All the information in the line the cursor is positioned on, up to the end of the screen, is moved one line downwards. The information from the last screen line is lost, and the line on which the cursor is positioned appears as a blank line. This process is called local downward scroll.

18. Line Delete

invoked by ESC L (1B 4D) or by ENQ = CTRL/E (05)
(this command does not exist at VT52 Terminal)

All the information of the line next to the line the cursor is positioned on, up to the end of the screen moves one line upwards. The information of the line the cursor is positioned on, is deleted, and on the last line of the screen a blank line appears. This process is called local up scroll.

Sound Signal

VDT 52S terminal transmits sound signals in the following situations: a) it received a specific command from the computer; b) it received a framing error from the computer.

The computer can command the terminal to transmit a sound signal using:

19. Sound Alarm

invoked by BEL (07)

Identification of the Terminal Type

Application programs that use the advanced characteristics of a CRT terminal - information erasure, cursor positioning, etc. - are generally too valuable to be dedicated to a certain terminal type. As long as the control sequence standardization will not be put in practice, such programs will have to be reconfigured each time when terminal one work with is changed. This configuration can be automatically made, if the terminal type can be automatically identified. Thus, the terminal configuration (type) coupled to a computer system, can be changed without programs revision.

20. Terminal Type Identification

invoked by ESC Z (1B 5A)

When receiving the ESC Z sequence, VDT 52S terminal transmits, as a response, a three-character ESCape sequence. This sequence sends to the computer the following informations:

- a) The terminal is on, connected to the computer and answers the commands.
- b) The terminal is a VDT 52S - compatible with VT52 with hard-copy from VT50 terminals family manufactured by Digital Equipment Corporation.

The transmitted ESCape sequence is:

ESC / K (1B 2F 4B)

During the response sequence transmission, the possible characters typed on the keyboard will be locally stored, so that the ESCape sequence not be interrupted by alien characters. The stored characters will be transmitted just after that.

Hold Mode

The Hold mode allows the operator to control the input/output data speed. This is very important, because the terminal can work on such a high communication speed so that the information received from the computer should remain on the screen few seconds only before scrolling up beyond the screen top limit, even if the operator has or has not the necessary time to read it. VDT 52S does the same when it is not in the hold mode.

Each time when, for any reasons, it cannot process computer data, the terminal automatically sends the X-OFF (13) character. After a while, when it is ready again to process data, it sends X-ON (11). The computer must promptly interrupt the emission when it receives X-OFF and to resume it from where it was, when it receives X-ON. When the programs put the terminal in the hold mode, it refuses to perform the scroll up. If it receives a scroll command, a LF in the last screen line, the terminal will save the LF to be performed later, and will send X-OFF to the computer. X-OFF means that the terminal is not ready for other computer data, as the terminal supposes that the operator is not ready for other data.

The operator informs the terminal that he is ready to see other data - that is, a new data line - by pressing the SCROLL key on the auxiliary keypad. Then the terminal processes the LF saved character that determines an up scroll. Then the terminal takes over from the local data buffer any character that would come from the computer, before this one was able to answer at X-OFF or suspend its emission. Any buffer character is displayed on the screen or, if concerns one command, it is performed as if it had just been received. The LF command is an exception, that stops the characters processing and waits until the operator presses SCROLL key again.

If the terminal processes all buffer characters, without meeting another LF, it transmits X-ON to the computer, in order to inform it that it is ready again to receive characters. It will display all the characters and perform all the commands, until it receives again a scroll command. Then it will send X-OFF again, will store LF and will wait again the operator to press SCROLL.

If, after the terminal sent X-OFF, the computer goes on transmitting so much as to fill the buffer, then, in order to avoid data loosing, the terminal performs the stored scroll in spite of its hold mode, extracts the characters from the buffer and interprets them reducing the delay. However, the terminal does not leave the hold mode; if either it happens to meet another scroll command in buffer or receives one from the computer it will not scroll and will start to store characters.

The operator presses the SCROLL key in order to ask a new line on the screen. The terminal translates this request into "start" and "stop" commands - X-ON and X-OFF - and sends them to the computer so that the terminal gets enough information to satisfy the operator's demand for another line.

The operator may press the SHIFT SCROLL key in order to ask a new data screen. The events sequence is similar to the action of the SCROLL key with the difference that this time the terminal performs 25 scrolls before stopping the computer data displaying.

Using the hold mode the programs can send the data to the terminal page-by-page. It is not necessary to have the evidence of the number of lines transmitted to the terminal since the last request as the terminal knows it and informs the computer itself.

21. Hold Screen Mode Selection invoked by ESC ((1B 5B)

The terminal gets in the hold screen mode. The data will not leave the screen without the operator's permission, obtained by pressing the SCROLL or SHIFT SCROLL keys. After getting in the hold mode, the first command to determine the information scroll will be not immediately processed, and the terminal will transmit X-OFF to the computer.

The hold mode remains active until the following command terminates it.

22. Hold Mode Exiting invoked by ESC \ (1B 5C)

The terminal leaves the hold mode. The data scroll will be allowed in order to make room to the data coming from the computer.

Semigraphic Mode

Besides the 96 printable characters in the ISO 646/ASCII set, the VDT 52S terminal can display another 32 special symbols. These symbols have been designed in order to represent the 32 control characters from the code. The modality of displaying these characters on the screen is of setting the terminal semigraphic mode.

Usually, the 5E-7E codes represent the small letters and other symbols. In the semigraphic mode, each code in this domain will produce one of the special symbols on the screen. The 20-5D codes are not affected. The symbols they represent can be displayed on the screen no matter if the terminal is or is not in this mode.

VDT 52S uses the control modes to mark the position of the special symbols in its internal memory. That is why the special symbols and the small letters can coexist on the screen. The special symbols will remain on the screen where they have been introduced even if the terminal semigraphic mode is reset.

23. Semigraphic Mode Actuate
invoked by ESC F (1B 46)

When receiving the codes in the 5E - 7E domain, these characters will be converted into special symbols before being displayed on the screen. The semigraphic mode remains set until the terminal receives the following command.

24. Semigraphic Mode Reset (Desactuate)
invoked by ESC 6 (1B 47)

The 5E - 7E codes resume their ISO 646/ASCII standard specifications.

Alternate Mode

The codes sent by the keys in the functional group are listed in the previous chapters, but in the VT52 mode there are two code sets which can be selected by the programs by transmitting these commands.

25. Alternate Mode Actuate
invoked by ESC = (1B 3D)

The terminal gets in the alternate mode for the functional group keys, where the ERASE-LINE, ERASE-TO-END and HOME keys transmit ESCape sequences.

The alternate mode will be desactuated either by the terminal restart or by the following command reception.

26. Alternate Mode Desactuate
invoked by ESK > (1B 3E)

Disable the alternate mode.

Normal Video/Reverse Video

In order to put into evidence parts of the text displayed on the screen, reverse video display may be used. The reverse video mode affects only the characters display. It does not affect the performance of the special commands which modify the displayed image (line or character insertion, line or character erase, screen erase, etc.).

27. Reverse Video Field Initiation
invoked by ESC M (1B 4E) or by S0 = CTRL/M (0E)
(for VT52 terminal only ESC M)

It initiates the display in the reverse video mode. The terminal remains in this state until it receives a command to return in normal video (ESC O), or until it receives an initialization command (ESC O). In this case, the cursor does not move.

28. Reverse Video Field End
invoked by ESC 0 (1B 4F) or by SI = CTRL/O (OF)
(for VT52 terminal only ESC 0)

It returns to the normal display mode. In this case, the cursor does not move.

Terminal Initialization

29. Initialization
invoked by ESC 0 (1B 30)
(this command does not exist to VT52)

All the terminal state variables are initialized.

So, the terminal enters ALPHA mode. The normal video mode is activated; the semi-graphic mode, alternate mode, and hold mode are inhibited. Besides, a screen erase operation is performed. Of course, the terminal operation remains under the influence of the hardware configuration switches which specify the transmission and reception speeds, the cursor shape (block or underlining), etc.

All the functional keys are initialized in the undefined status. The key-click option is activated.

Also, all the state variables used in the graphic operation modes are initialized, as following:

- the graphic current address (used in the VECTOR, BLOCK, MARKER and PAINT modes) is placed in the screen's lower left corner (graphic address 0,0);
- the current graphic input address (used in the GIN mode) is also placed in the screen's lower left corner;
- the graphic scaling factors are initialized with the following values: SX = 1/2 in the horizontal direction and SY = 30/64 in the vertical direction;
- the OR graphic attribute is activated;
- the linear pattern used for dashed lines drawing and the bidimensional pattern used in BLOCK and PAINT modes are initialized with all bits set.

In short, through the ESC 0 command, the terminal comes in the state obtained immediately after it was powered on.

30. Audible Signal at Key Pressing (Key-click)

Calling sequence: ESC, '2' = 1BH, 32H

This command enables or disables the audible confirmation for key pressing. During initialization procedure the key-click option is activated.

31. Page Length Modification

Calling sequence: ESC, '8' = 1BH, 38H

This command modifies the displayed page dimension, from 25 lines to 24 lines and vice-versa. After the initialization, the page length is 25 lines. The command is followed by a clear screen operation.

32. Line Length Modification

Calling sequence: ESC, '9' = 1BH, 39H

This command modifies the displayed line length, from 80 to 85 characters and vice-versa. After the initialization, the line is 85 character long. The command is followed by a clear screen operation.

33. Continuous Hard Copy Mode

Calling sequence: ESC, 'X' = 1BH, 58H

This command enables/disables the continuous hard copy mode of the VDT 52S terminal. When this mode is active, all the displayed characters are copied on the local printer, connected through the SIOB serial interface. In addition, the following control characters are also copied to the printer: CR = 0DH for carriage return, LF = 0AH for line feed, FF = 0CH for new page, HT = 09H for horizontal tabulation. The printer tabulation positions are the same as on the screen: a tab at every 8 characters.

The other control characters as well as the ESCape sequences used in the alphanumeric mode, modify only the screen information and they are filtered when transmitting to the printer.

34. Screen Alphanumeric Copy to the Printer

Calling sequence: ESC, 'P' = 1BH, 50H

This command causes the copy of alphanumeric information on the display to the local printer. The displayed graphic information, which does not correspond to printable characters, is not printed. During the copy procedure, the screen operations are inhibited, but the communication with the computer is not interrupted.

NOTE. The alphanumeric copy of the screen to the local printer is also performed when the user presses the PRINT key on the auxiliary keyboard. No information is sent to the computer during this operation.

35. Screen Graphic Copy to the Printer

Calling sequence: ESC, CTRL/W = 1BH, 17H

This command causes integral copy of the screen graphic and alphanumeric information on the CD 9335 local printer. The copy operation is performed at pixel level, according to the 9335 protocol for graphic transmission. During the copy procedure, the screen operations are inhibited, but the communication with the computer is not interrupted.

NOTE. The graphic copy of the screen to the local printer is also performed when the user presses the SHIFT PRINT key on the auxiliary keyboard. No information is sent to the computer during this operation.

36. Functional Key Definition

Calling sequence: ESC, '_', key, count, d1, d2, dn

This command defines or redefines the sequence of characters generated by one of the 32 softkeys F1 ... F32 present on the VDT 52S keyboard. This sequence contains a variable number of characters, defined as follows:

- ESC, '_' = 1BH, 5FH are fixed codes;
- the 3rd byte has the following bit configuration:

KEY = P 1 1 . k k k k k

where P is the parity bit, and the last 5 bits identify the softkey to be defined:

k k k k k = 00000 - F1 key
 00001 - F2 key
 00010 - F3 key
 .
 .
 11111 - F32 key

- the 4th byte has the following bit configuration:

count = P 1 c c c c c c

where the last 6 bits (cccccc) determine the length of the character sequence (0 ... 63) which will be associated to the softkey.

- then the terminal is waiting for n codes d1, d2, ... dn, where n has the binary encoding ccccc. This sequence is stored in the terminal RAM memory and will be transmitted to the computer after each pressing of the associated softkey.

There are no restrictions concerning the d1, d2, ... dn codes: they usually represent printable characters, but control codes or ESC sequences may also be included.

As you can see above, the maximum length of a sequence generated by a softkey is 63 codes, and the minimum length is 0 (as if the softkey has not been defined). In addition, there is another restriction resulting from the RAM memory dimension included in the terminal: the total length of the sequences defined for all the 32 softkeys may not exceed 511. If this number is exceeded during the definition of a functional key, the additional codes in the sequence are lost and only the first part of the sequence will be associated to the softkey.

When turning on the terminal or after an initialization command (ESC, '0'), all the softkeys are not defined (do not transmit anything to the computer when they are depressed), but each of them may be defined and redefined as many times as necessary by the above mentioned procedure.

37. Current Alphanumeric Position Transmission

Calling sequence: ESC, ENQ = 1BH, 05H

After receiving the ESC, ENQ sequence from the computer, the VDT 52S terminal (in the alphanumeric operating mode) will transmit to the computer the following 6 byte sequence:

30H, XHigh, XLow, YHigh, YLow, 0DH

where the first byte 30H indicates that the terminal is in the alphanumeric mode (this byte has a different value for other operating modes), the last byte 0DH is fixed, and the four middle bytes represent an encoding of the graphic address of the lower left corner of the alphanumeric cursor.

The bit configurations of the 4 address bytes will be described in chapter 8.

This operation has no noticeable effect on the screen.

38. VECTOR Mode Selection

Calling sequence: CTRL/] = 1DH

After receiving the GS = CTRL/] = 1DH code, the alphanumeric cursor disappears and the VDT 52S terminal enters the VECTOR operating mode. In this mode, the terminal will use the information received from the computer in order to determine the X,Y addresses of some points on the screen, and will connect the selected points with straight lines (vectors). The VECTOR operating mode will be fully described in chapter 4.

39. MARKER Mode Selection

Calling sequence: CTRL/\ = 1CH

The received FS = CTRL/\ = 1CH code causes the VDT 52S terminal entering the MARKER operating mode. The subsequently received data will be used to determine the X,Y addresses of some points on the screen, where some special graphic symbols (markers) will be displayed. There are 11 different markers that will be described in the dedicated chapter 6.

40. BLOCK Mode Selection

Calling sequence: CTRL/ = 1EH

The RS = CTRL/ = 1EH code causes the terminal to enter BLOCK operating mode. The terminal will use the information received from the computer in order to define the X,Y addresses of some screen points with the following purpose: any of 2 consecutive addresses are considered to be the corners of a screen rectangle whose contents will be modified (unconditional filling, unconditional clearing, point by point reversal or filling with a bidimensional 16x16 points pattern). For further details see the dedicated chapter 5.

41. PAINT Mode Selection

Calling sequence: CTRL/P = 10H

The PAINT operating mode is optional. After entering the PAINT mode, the terminal will use the received information in order to define the X,Y addresses of some screen points with the following purpose: each point is located inside a closed contour which will be unconditionally filled or it will be filled with a bidimensional 16x16 point pattern. The terminal firmware will search and will fill the "smallest" closed contour encircling the initial point; if it does not exist, the whole screen will be filled. See chapter 7. for further details.

42. GIN Mode Selection

Calling sequence: ESC,CTRL/Z = 1BH, 1AH

This sequence causes the graphic cursor appearance; it consists of 2 blinking vectors which intersect each other in the graphic input current position. Upon initialization, the graphic input position is located at address 0,0 (the lower-left corner on the screen). Using special keys from the auxiliary keyboard, the user can modify the graphic input current position (the graphic cursor position). After selecting the desired graphic position, the user can command the transmission of its address to the computer, by pressing a key on the main keyboard. For further details see the dedicated chapter 8.

SECTION III. GRAPHIC OPERATION MODES

Besides the above mentioned alphanumeric mode, the VDT 52S terminal may operate in four graphic modes: VECTOR, MARKER, BLOCK and PAINT (the last being optional). The terminal uses the information received from the computer for graphic operations on the displayed image. The sixth operating mode (GIN - graphic input) is used for graphic input, when the terminal transmits graphic information to the computer (a graphic address encoding), the displayed image being not modified.

Using the four graphic modes, VECTOR, MARKER, BLOCK and PAINT, most of the data received by the terminal form the encoding of X,Y addresses of screen points. The VDT 52S screen resolution is 512 horizontal points and 256 vertical points. The graphic origin is the screen lower-left corner.

A complete graphic address consists of 4 data bytes: High Y, Low Y, High X and Low X, received in that order.

The 4 bytes have the following bit configurations:

```
High Y = P 0 1 Y Y Y Y Y
Low Y = P 1 1 y y y y y
High X = P 0 1 X X X X X
Low X = P 1 0 x x x x x
```

where:

- P is the parity bit of each received byte
- YYYYY are the most significant 5 bits of the vertical address
- yyyyy are the least significant 5 bits of the vertical address
- XXXXX are the most significant 5 bits of the horizontal address
- xxxxx are the least significant 5 bits of the horizontal address

Therefore, the XXXXXxxxxx horizontal and YYYYYyyyyy vertical addresses sent by the computer to the terminal are defining an addressable space of 1024 x 1024 points. This is the TEKTRONIX 40xx terminals screen resolution. As the VDT 52S screen resolution is only 512x256 points, a scaling (multiplication by a subunitary factor) of the received addresses is needed. The next paragraph will present the scaling operation.

After receiving the 4 bytes sequence above described, the current graphic position is modified, its new value being (XXXXXxxxxx, YYYYYyyyyy). The current graphic position is the same for all the graphic output operating modes (VECTOR, BLOCK, MARKER, PAINT), but it does not affect the graphic input position (GIN), as well as the current alphanumeric position. The current graphic position is maintained, even if the terminal leaves temporarily the graphic mode. The current graphic position is initialized with the value (0,0) (screen lower-left corner).

The 4 bytes sequence defining a graphic address can be reduced to 3, 2 or 1 data byte(s), but it must always contain the Low X byte. If a byte of the new transmitted address does not differ from the previous address corresponding byte, then it can be omitted under certain circumstances. The following table shows which bytes must be sent in response to specific bytes changes:

| Bytes which change | Bytes which must be sent | | | |
|--------------------|--------------------------|-------|--------|-------|
| | High Y | Low Y | High X | Low X |
| High Y | # | | | # |
| Low Y | | # | | # |
| High X | | # | # | # |
| Low X | | | | # |

For example, if Low Y changes, Low Y and Low X must be transmitted; if High Y and Low Y change, then High Y, Low Y and Low X must be transmitted.

3.1 GRAPHIC COORDINATES SCALING

For a better compatibility with already existing graphic applications (written for other graphic terminals), the VDT 52S includes the facility of graphic coordinates scaling. The horizontal and vertical scaling factors are independent and are received from the computer through the following sequence:

ESC, 's', X factor, Y factor

where:

- the ESC, 's' = 1BH, 73H codes are fixed
- the X factor byte defines the horizontal scaling factor and has the following bit configuration:

X factor = P 1 x x x x x x

If xxxxxx = 000000, then the horizontal scaling factor is SX = 1 (no scaling), otherwise the NX = xxxxxx 6-bit integer number defines the subunitary horizontal scaling factor SX = NX/64.

- the Y factor byte defines the vertical scaling factor and has the following bit configuration:

Y factor = P 1 y y y y y y

If yyyyyy = 000000, then the vertical scaling factor is SY = 1 (no scaling), otherwise the NY = yyyyyy 6-bit integer defines the subunitary vertical scaling factor SY = NY/64.

After defining the SX and SY scaling factors, any graphic coordinate received by the terminal in the VECTOR, MARKER, BLOCK and PAINT modes is multiplied by the corresponding scaling factor, before being used for a specific graphic operation. Also, the graphic coordinates defined by the user in the GIN Mode (graphic input) are multiplied by the reverse scaling factors 1/SX and 1/SY before being transmitted to the computer.

After the received graphic coordinates scaling the VDT 52S terminal performs a truncation of the horizontal addresses to 9 bits and of the vertical addresses to 8 bits, in order to fit them in the 512x256 addressable space of the screen. Therefore, if the scaling factors are not well chosen, the scaled coordinates could be too high, the truncation operation will destroy significant bits in the received address, and the image transmitted by the computer will appear distorted on the screen.

Upon terminal initialization the $SX = 32/64 = 1/2$, $SY = 30/64$ scaling factors are defined.

3.2 GRAPHIC ATTRIBUTES

The VDT 52S terminal can perform each graphic operation in different ways, depending on the active graphic attribute. For example, the graphic attributes indicate if the vectors are drawn in the normal way or erased; they also indicate if the rectangular block or closed contour filling is unconditionally performed (all inside points are written) or the filling is performed using a bidimensional pattern.

Four graphic attributes may be used: OR, XOR, DEL and PATTERN, which control the VECTOR, MARKER, BLOCK and PAINT operating modes. We present below the selecting sequence as well as the effect of each graphic attribute upon the four operating modes.

The OR graphic attribute is enabled by the terminal when receiving the sequence:

ESC, DC2 = ESC, CTRL/R = 1BH, 12H

This attribute causes the straight lines normal drawing in the VECTOR mode (lighting of all points generated,) unconditional filling of screen rectangular areas in the BLOCK mode, normal display of all graphic symbols generated in MARKER mode and lighting of all points inside the contours filled in PAINT mode.

The OR attribute is enabled upon terminal initialization (after turning on the terminal or after an ESC, 'O' command).

The XOR graphic attribute is enabled by the terminal when receiving the sequence:

ESC, DC3 = ESC, CTRL/S = 1BH, 13H

This attribute causes the reverse drawing of straight lines in the VECTOR mode, that is the status of each generated pixel is reversed. In the BLOCK mode, the selected rectangular area turns into reverse video, and in the MARKER mode the pixel status of the generated graphic symbols is reversed. The XOR attribute is not used in the PAINT mode.

The XOR attribute has a special feature, namely, when used in two subsequent operations (vector drawing or rectangular area reversal), it restores the screen image in its initial form.

The DEL graphic attribute is enabled through the sequence:

ESC, DC1 = ESC, CTRL/Q = 1BH, 11H

This attribute causes straight lines deletion in the VECTOR mode, so that a drawing operation is noticeable only if the screen background is lighted. In the BLOCK mode, the selected rectangular area is erased, and in the MARKER mode all the generated graphic symbols points are reset. The DEL attribute is not used in the PAINT mode.

The PATTERN graphic attribute is enabled through the sequence:

ESC, DC4 = ESC, CTRL/T = 1BH, 14H

This attribute causes, in the VECTOR mode, the straight dashed or dotted lines, depending on a 16 points unidimensional pattern. This pattern is used circularly for all the points generated during vector drawing. The unidimensional pattern definition is presented in the next paragraph.

In the BLOCK mode, the PATTERN attribute causes the selected rectangular area filling with a 16x16 points bidimensional pattern. This pattern is used circularly in both directions (X and Y) in the filling operation. The bidimensional pattern definition is presented in the next paragraph.

In the MARKER mode this attribute is not used.

In the PAINT mode, the PATTERN attribute causes the filling of the interior of a connexed contour with the 16x16 points bidimensional pattern (the same as that used in the BLOCK mode).

3.3 UNIDIMENSIONAL AND BIDIMENSIONAL PATTERNS

The unidimensional pattern is used for the generation of dashed or dotted straight lines and is defined through the following 6-byte sequence:

ESC, 'p', 11, 12, 13, 14

where:

1

- ESC, 'p' = 1BH, 70H - fixed codes;
- 11, 12, 13, 14 data bytes have the following bit configurations:

11 = P1 xx aaaa
12 = P1 xx bbbb
13 = P1 xx cccc
14 = P1 xx dddd

where:

- P is the parity bit
- bits xx are not used
- the least significant 4 bits of each byte define the 16 bits one-dimensional pattern: cccc dddd aaaa bbbb.

The two-dimensional pattern used for filling the rectangular areas in the BLOCK mode, and filling of closed contours in the PAINT mode is defined through the following 66-byte sequence:

ESC, 'q', d1, d2, ... d64

where:

- ESC, 'q', = 1BH, 71H - fixed codes;
- d1, d2, ... d64 data bytes have the following bit configurations:

d1 = P1 xx aaaa
d2 = P1 xx bbbb
d3 = P1 xx cccc
d4 = P1 xx dddd
:
:
:
d61 = P1 xx tttt
d62 = P1 xx uuuu
d63 = P1 xx vvvv
d64 = P1 xx wwww

where:

- bits xx are not used (don't care)
- the least significant 4 bits of each byte define the 16x16 bits bidimensional pattern:

aaaa bbbb cccc dddd
..... 16 lines
tttt uuuu vvvv wwww

Upon terminal initialization, both the unidimensional and the bidimensional patterns contain only 1 bits, so that the PATTERN attribute has the same effect as the OR attribute. This situation is maintained until the patterns are modified through the above described ESC, 'p', ... or ESC, 'q', ... sequences.

SECTION IV. VECTOR OPERATING MODE

In the VECTOR operating mode, the VDT 52S terminal draws straight lines (vectors) on the screen. The VECTOR mode is selected through the GS = 1DH code, received from the computer.

After entering the VECTOR mode, the terminal interprets the data received from the computer as X, Y addresses of some screen points. The address encoding mode has been described above, as well as the scaling operation that the computer performs on the decoded addresses, using SX and SY scaling factors defined through the ESC, 's', ... sequence.

The effective drawing operation starts after receiving the last Low X byte of the sequence defining a graphic address. This byte is present in any graphic addressing sequence, even if it is reduced to 3, 2 or 1 byte, as you can see from the table in chapter 3.

The vector connects the previous graphic position point to the new defined graphic position point (whose last address byte is Low X). In addition, the new defined graphic position becomes the current position and it will be the starting point of a subsequently generated vector.

The first graphic address received just after entering the VECTOR mode (after GS = 1DH), does NOT cause vector drawing, but it is used only for the current graphic address definition. The second and any subsequent address received after a GS command result in a written vector (up to exiting VECTOR mode or up to another GS). For example, a sequence having the form:

```
GS, adr1, adr2, ... adrn, GS, adr(n+1), adr(n+2), .... adr m
```

will generate 2 broken lines on the screen (2 vector strings) between the adr1, adr2, ... adr n points and, respectively, adr(n+1), adr(n+2), ... adr m.

As an exception to this rule, we mention that the BEL = 07H control code, received immediately after the GS command, forces vector drawing in response to the first graphic address. This vector starting point is the last graphic address defined during previous operation in a graphic mode (VECTOR, BLOCK, MARKER or PAINT). For example, the sequence:

```
GS, adr1, adr2, ... adr n, CR,  
[alphanumeric mode operation],  
GS, BEL, adr (n+1), adr (n+2), ... adr m
```

will generate on the screen a SINGLE broken line (vector string) connecting the points adr1, adr2, ... adr n, adr (n+1), adr (n+2), ... adr m (besides the characters displayed during the ALPHA operating mode).

Note that the current graphic address is the same for VECTOR, BLOCK, MARKER and PAINT operating modes, but it is not related to the current alphanumeric address. The graphic current address is initialized at (0,0) (screen lower-left corner), after turning on or after an ESC, '0' sequence.

The vectors drawing is controlled by the current graphic attribute OR, XOR, DEL or PATTERN. The OR attribute causes the vectors normal drawing, the DEL attribute is used for vectors deletion, the XOR attribute causes vectors reverse drawing and the PATTERN attribute generates broken or dotted straight lines, according to a 16 bits linear pattern previously defined. The graphic attribute or the drawing linear pattern may be modified in the VECTOR operating mode.

The VDT 52S terminal controls the following control codes in the VECTOR operating mode:

- * GS = CTRL/] = 1DH - modifies the current graphic position, remains in VECTOR mode
- * RS = CTRL/~ = 1EH - BLOCK mode selection
- * FS = CTRL/\ = 1CH - MARKER mode selection
- * DLE = CTRL/P = 10H - PAINT mode selection (optional)
- * ESC = CTRL/[= 1BH - special sequence initialization
- * CR = ODH - selects ALPHA mode, performs CR
- * US = CTRL/_ = 1FH - selects ALPHA mode, keeping the current position
- * BEL = CTRL/G = 07H - forces vector drawing immediately after GS

In the VECTOR operating mode, the following special sequences (with ESC) are recognized:

- * ESC,DC1 = 1BH, 11H - enables DEL (vector deletion) graphic attribute
- * ESC,DC2 = 1BH, 12H - enables OR (normal vector drawing) graphic attribute
- * ESC,DC3 = 1BH, 13H - enables XOR (reversed vector drawing) graphic attribute
- * ESC,DC4 = 1BH, 14H - enables PATTERN (bidimensional pattern block filling) graphic attribute
- * ESC,ETB = 1BH, 17H - performs screen graphic copy on the CD 9335 local printer
- * ESC,CTRL/Z = 1BH, 1AH - enters the GIN mode and enables the graphic cursor
- * ESC,FF = 1BH, 0CH - enters the ALPHA mode and erases the screen
- * ESC,ENQ = 1BH, 05H - initiates the transmission of the current graphic address to the computer
- * ESC,'s', ... = 1BH, 73H... - modifies the horizontal and vertical scaling factors
- * ESC,'p', ... = 1BH, 70H, ... - modifies the unidimensional pattern used for dashed lines
- * ESC,'_', ... = 1BH, 5FH, ... - defines the sequence generated by a softkey

Most of the above-mentioned commands have been presented in the previous chapters. The new commands will be presented below.

4.1 ALPHA MODE SELECTION

The transition from VECTOR mode to ALPHA mode is performed as a response to the following commands received from the computer:

CR = 0DH
US = CTRL/ = 1FH
ESC, FF = CTRL/[, CTRL/L = 1BH, 0CH

The CR command selects the ALPHA mode and performs the CR operation from the last alphanumeric position.

The US command selects the ALPHA mode and leaves the alphanumeric cursor in the last graphic position of the VECTOR mode.

The ESC, FF command selects the ALPHA mode, erases the screen and homes the alphanumeric cursor.

The user may also restore the ALPHA mode using some special keys:

- PAGE key selects the ALPHA mode, erases the screen and homes the cursor;
- SHIFT PAGE key selects the ALPHA mode and homes the cursor.

No code is transmitted to the computer when pressing the PAGE and SHIFT PAGE keys.

4.2 CURRENT GRAPHIC POSITION TRANSMISSION

Calling sequence: ESC, ENQ = CTRL/[, CTRL/E = 1BH, 05H

After receiving this sequence in the VECTOR mode, the VDT 52S terminal will transmit the following 6 codes sequence:

32H, XHigh, XLow, YHigh, YLow, 0DH

The first code 32H identifies the VECTOR mode, the last code 0DH is fixed, and the four middle codes represent an encoding of the current graphic address. The bit configurations for these 4 address bytes will be presented in chapter 8.

SECTION V. BLOCK OPERATING MODE

In the BLOCK operating mode, the VDT 52S terminal performs elementary graphic operations on screen rectangular block. The BLOCK mode is selected by the RS = 1EH code received from the computer.

The received addresses decoding and scaling operations are performed as in the VECTOR mode. After receiving the Low Y byte of the sequence defining the graphic address, an elementary graphic operation is executed on a screen rectangular block. The last two graphic addresses received from the computer represent the positions of two diagonally opposite corners of the rectangle, fixing its position on the screen.

The graphic operation depends on the current graphic attribute, as follows:

- OR attribute fills the block unconditionally
- DEL attribute erases the block unconditionally
- XOR attribute causes block video reversal
- PATTERN attribute causes block filling with a 16x16 bits bidimensional pattern

The graphic attribute or the filling bidimensional pattern modification can be also performed in the BLOCK operating mode.

The VDT 52S terminal recognizes the following control codes in the BLOCK operation mode:

- * GS = CTRL/] = 1DH - VECTOR mode selection
- * RS = CTRL/~ = 1EH - modifies the current graphic position, remains in the BLOCK mode
- * FS = CTRL/\ = 1CH - MARKER mode selection
- * DLE = CTRL/P = 10H - PAINT mode selection (optional)
- * ESC = CTRL/[= 1BH - special sequence initialization
- * CR = 0DH - ALPHA mode input, performs CR operation
- * US = CTRL/_ = 1FH - ALPHA mode selection, maintaining the current position
- * BEL = CTRL/G = 07H - forces one block filling or deletion immediately after RS

In the BLOCK operating mode, the following special sequences are recognized (with ESC):

- * ESC,DC1 = 1BH, 11H - enables DEL (block deletion) graphic attribute
- * ESC,DC2 = 1BH, 12H - enables OR (block filling) graphic attribute
- * ESC,DC3 = 1BH, 13H - enables XOR (reverse video block) graphic attribute
- * ESC,DC4 = 1BH, 14H - enables PATTERN (bidimensional pattern block filling) graphic attribute
- * ESC,ETB = 1BH, 17H - initiates screen graphic copy to the DC 9335 local printer
- * ESC,CTRL/Z = 1BH, 1AH - enters the GIN mode and enables the graphic cursor
- * ESC,FE = 1BH, 0CH - enters the ALPHA mode and erases the screen

- * ESC,ENQ = 1BH, 05H - initiates the transmission of the current graphic address to the computer
- * ESC,'s', ... = 1BH, 73H... - modifies the horizontal and vertical scaling factors
- * ESC,'q', ... = 1BH, 71H, ... - modifies the bidirectional pattern used for blocks filling
- * ESC,'_', ... = 1BH, 5FH, ... - defines the sequence generated by a softkey

Most of the above-mentioned commands have been described in the previous chapters. The transition from BLOCK operating mode into ALPHA operating mode is performed in the same manner as the transition from VECTOR operating mode into ALPHA operating mode, provided that the first transmitted byte be 33H, in order to identify the BLOCK operating mode.

SECTION VI. MARKER OPERATING MODE

In the MARKER operating mode, the VDT 52S terminal displays some small special graphic symbols, at the addresses transmitted by the computer. The graphic symbols display begins with the first address received after FS.

The received addresses decoding and scaling operations are performed as for the VECTOR operating mode. After receiving the Low Y byte of the sequence defining a graphic address, the terminal generates on the screen, at the defined graphic address, a marker which indicates the current position. There are 11 possible marker configurations, which are described in paragraph 6.1. Any of these configurations may be selected by a special sequence received from the computer.

The display of a graphic symbol depends on the current graphic attribute. For example:

- OR attribute displays marker
- DEL attribute deletes all generated points; in this case, the effect can be seen only if the screen background is lighted
- XOR attribute causes all generated points to be video reversed
- PATTERN attribute is not used in MARKER operating mode

In the MARKER operating mode, the VDT 52S terminal recognizes the following control codes:

- * GS = CTRL/] = 1DH - VECTOR mode selection
- * RS = CTRL/~ = 1EH - BLOCK mode selection
- * FS = CTRL/\ = 1CH - remains in MARKER mode
- * DLE = CTRL/P = 10CH - enters the PAINT mode (optional)
- * ESC = CTRL/[= 1BH - special sequence initialization
- * CR = ODH - enters the ALPHA mode, performs CR
- * US = CTRL/_ = 1FH - enters the ALPHA mode, leaving the alpha cursor in the last graphic address

The following special sequences (with ESC) are recognized in MARKER operating mode:

- * ESC,'m', ... = 1BH,6DH, ... - marker selection
- * ESC,DC1 = 1BH,11H - enables the DEL (marker deletion) graphic attribute
- * ESC,DC2 = 1BH,12H - enables OR (marker generation) graphic attribute
- * ESC,DC3 = 1BH,13H - enables XOR (marker reverse drawing) graphic attribute
- * ESC,ETB = 1BH,17H - initiates screen graphic copy to the CD 9335 local printer
- * ESC,CTRL/Z = 1BH,1AH - enters GIN mode and enables the graphic cursor
- * ESC,FF = 1BH, 0CH - enters ALPHA mode and erases screen
- * ESC,ENQ = 1BH,05H - initiates current graphic address transmission to the computer
- * ESC,'s', ... = 1BH,73H, ... - modifies horizontal and vertical scaling factors
- * ESC,'_', ... = 1BH,5FH, ... - defines the sequence generated by a softkey

Most of the above-mentioned commands have been described in the previous chapters. The transition from MARKER operating mode into ALPHA operating mode is performed as the transition from VECTOR operating mode into ALPHA operating mode. The current graphic address transmission is performed in the same manner as in the VECTOR mode, provided that the first transmitted byte be 34H, identifying the MARKER operating mode.

6.1 MARKER SELECTION

The graphic symbols configuration is selected by the following 3 bytes sequence, received from the computer:

ESC, 'm', mrk

where ESC, 'm' = 1BH, 6DH are fixed codes, and the third byte contains the following bit configuration:

mrk = P 1 xx nnnn

where:

- P is the parity bit
- xx are non-used bits (don't care)
- the last four bits nnnn define an integer number between 0 and 10 which select the marker to be used. If this number is greater than 10, marker 0 will be selected. The marker 0 is also selected after terminal initialization.

The pixel configurations of the 11 possible markers are shown on the following page.

Marker 0 :



Marker 1 :



Marker 2 :

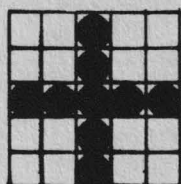

Marker 3 :

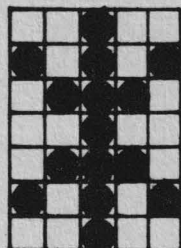

Marker 4 :

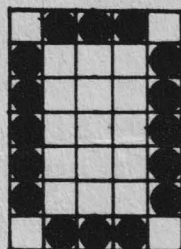

Marker 5 :

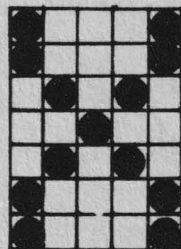

Marker 6 :

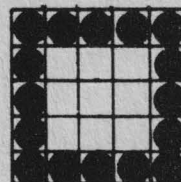

Marker 7 :

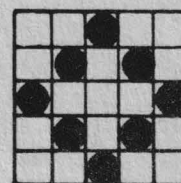

Marker 8 :

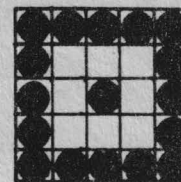

Marker 9 :

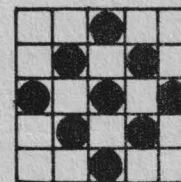

Marker 10 :

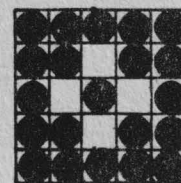

SECTION VII. PAINT OPERATING MODE

The PAINT operating mode is optional. In the minimum version, the terminal is provided with 6K PROM memory and 1K RAM memory, and this operating mode is not included. For PAINT mode implementation 8K PROM and at least 20K RAM configurations are needed.

In the PAINT operating mode, the VDT 52S terminal performs closed contours filling on the screen, starting from a seed point, whose address is received from the computer. The terminal firmware will search and will fill the "smallest" closed contour encircling the initial point. If a contiguous margin does not exist, the whole screen will be filled. Note that some "islands" are allowed inside the filled area; these "islands" are not affected by the filling operation.

The active graphic attribute controls the contour filling operation as follows: if the active attribute is OR, an unconditional filling occurs (all inside points are lighted) and if the active attribute is PATTERN, then a 16x16 points bidimensional pattern previously defined is used. The XOR and DEL attributes are not used in the PAINT operating mode.

The PAINT operating mode is selected by the DLE = 10H code received from the computer. After entering the PAINT mode, the terminal is waiting the 1-4 bytes address, which marks on the screen the initial point ("seed"). The received address decoding and scaling are performed as for the VECTOR operating mode. The effective filling operation is performed after receiving the Low Y byte of each address.

NOTE 1. If the initial point is already on, the filling operation is quickly ended, without modifying the displayed image.

NOTE 2. The non-convex contour filling operation makes extensive use of terminal RAM memory. The used RAM memory dimension increases with the number of "islands" inside the contour. If the "islands" number is too high, it is possible for the RAM memory to be exhausted, therefore the filling operation is partially performed.

In the PAINT operating mode the VDT 52S terminal recognizes the following control codes:

| | | |
|---|--------------------|-------------------------------------------------------------------------------|
| * | GS = CTRL/] = 1DH | - VECTOR mode selection |
| * | RS = CTRL/~ = 1EH | - BLOCK mode selection |
| * | FS = CTRL/\ = 1CH | - MARKER mode selection |
| * | DLE = CTRL/P = 10H | - remains in the PAINT mode |
| * | ESC = CTRL/[= 1BH | - special sequence initialization |
| * | CR = ODH | - enters the ALPHA mode, performs CR |
| * | US = CTRL/_ = 1FH | - enters the ALPHA mode, leaving the alpha cursor in the last graphic address |

The following special sequences (with ESC) are recognized in the PAINT operating mode:

- * ESC,DC2 = 1BH,12H - enables OR graphic attribute (unconditional filling)
- * ESC,DC4 = 1BH,14H - enables PATTERN graphic attribute (pattern filling)
- * ESC,ETB = 1BH,17H - initiates screen graphic copy on the CD 9335 local printer
- * ESC,CTRL/Z = 1BH,1AH - enters GIN mode and enables the graphic cursor
- * ESC,FF = 1BH,0CH - enters ALPHA mode and erases
- * ESC,ENQ = 1BH,05H - initiates current graphic address transmission to the computer
- * ESC,'s', ... = 1BH,73H, ... - modifies horizontal and vertical scaling factors
- * ESC,'_', ... = 1BH,5FH, ... - defines the sequence generated by a softkey
- * ESC,'q', ... = 1BH,71H, ... - defines the 16x16 points bidirectional pattern used in the filling operations

Most of the above-mentioned commands have been described in the previous chapters. The transition from PAINT operating mode into ALPHA operating mode is performed as the transition from VECTOR operating mode into ALPHA operating mode. The current graphic address transmission is performed in the same manner as in the VECTOR operating mode, provided that the first transmitted byte be 35H, for identifying the PAINT operating mode.

SECTION VIII. GIN OPERATING MODE (GRAPHIC INPUT)

The GIN operating mode allows the VDT 52S terminal interactive graphic use. In the GIN operating mode, the user can select an address on the screen and can command the terminal to transmit this address to the computer, for further graphic processings.

The GIN mode is entered by the ESC, SUB = 1BH, 1AH command received from the computer. After entering the GIN mode, a graphic cursor is displayed, under the form of 2 perpendicular blinking vectors. The 2 vectors crossing point defines the graphic input current position. This position does not depend on the current graphic position, used in the graphic output modes (VECTOR, BLOCK, MARKER, PAINT), as well as on the current alpha-numeric position. The graphic input current position is initialized at (0,0) (screen lower-left corner), after terminal turning on, or after an ESC, '0' initialization command.

The user may modify the graphic input current position (the graphic cursor position) by means of some special keys included in the auxiliary keyboard. The "arrow keys" may be used for cursor moving in the four main directions. The 1,2,3,4,6,7,8,9 keys of the auxiliary keyboard may be used for horizontal, vertical, and diagonal graphic cursor moving, as following:



When the keys are pressed in the normal way, the cursor is moved with a single point, with the SHIFT key pressed simultaneously, the cursor moves 8 points, and with the CTRL key pressed simultaneously, the cursor moves 64 points.

After placing the graphic cursor in the desired position, the user may command the transmission of this address to the computer, by pressing a key on the main keyboard. The last pressed key code, together with the graphic input current address are transmitted to the computer by the following 6 bytes sequence:

Key, XHigh, XLow, YHigh, YLow, ODH

where

- key is the last pressed key code
- ODH code is fixed
- the four middle bytes represent an encoding of the graphic input current address, as follows:

```
XHigh = P 0 1 X X X X X
XLow  = P 0 1 x x x x x
YHigh = P 0 1 Y Y Y Y Y
XHigh = P 0 1 y y y y y
```

Thus, the computer receives the 10 bits addresses XXXXXxxxxx (horizontal) and YYYYYyyyyy (vertical).

The proportions between the terminal physical address space and the computer logical address space is SX on the 1BH code received from the computer.

The received addresses decoding and scaling operations are performed as in the 's', ... sequence, the physical (screen) coordinates of the selected graphic position are multiplied by the reversed scaling factors 1/SX and 1/SY before the transmission.

After the graphic current input address transmission, the terminal enters ALPHA mode, resetting the cursor in the last ALPHA position.

The VDT 52S terminal has a second possibility for transmitting the graphic current input address, after receiving the ESC, ENQ = 1BH, 05H sequence from the computer. In this case, the terminal sends the following 5-byte sequence:

XHigh, XLow, YHigh, YLow, ODH

where the 4 address bytes have the above-mentioned configurations. After transmission, the terminal enters ALPHA mode.

The GIN mode may also be terminated without transmitting the current address. After receiving the CR = ODH code from the computer, the terminal leaves the GIN mode, enters the ALPHA mode and performs a CR operation. When receiving the ESC, FF = 1BH, 0CH sequence, the terminal enters the ALPHA mode and erases the screen.

The user may terminate the GIN mode without transmitting to the computer, by pressing the PAGE key, and the terminal enters the ALPHA mode and erases, or by pressing the SHIFT PAGE key, in which case the terminal enters ALPHA mode and homes the cursor.

During GIN mode, the VDT 52S terminal recognizes the following special sequences and codes:

- * CR = ODH - enters ALPHA mode and performs CR
- * ESC,FF = 1BH, 0CH - enters ALPHA mode and erases the screen
- * ESC,ENQ = 1BH, 05H - transmits the graphic input current address to the computer

SECTION XI. INSTALLATION

9.1 INITIAL PREPARATION

The space-saving design of the VDT 52S has proven to be beneficial for almost every terminal site. Its small size is ideally suited to those work environments where physical space is limited.

The physical dimensions of the VDT 52S are shown in Figure 9-1, page 54. The basic requirements for installation are as follows:

- Table or desk mounting
- Standard three-pronged 220 VAC power outlet.
- Cable connection to the computer, data set or modem; serial printer, or other auxiliary device. If connection to a remote computer is desired, a modem or data set is usually required.

CAUTION

Allow the VDT 52S to adjust to severe changes in the environment before applying power. This will reduce the possibility of internal condensation, which could impair its operation.

9.1.1 Line Voltage

The VDT 52S is shipped ready to operate at 220 VAC.

9.1.2 Set-Up Mode Preparation

The operating configurations of the VDT 52S are controlled by "switches" and have been pre-set at factory to the default conditions as indicated by "*" in Table 9-1, page 53.

Parameters of the host computer must be determined before the terminal can be used.

9.1.3 Keyboard Plug-In

Before applying power to the terminal, plug the keyboard coiled cord into the connector on the back of the monitor. Refer to Figure 9-2, page 55 for connector location.

TABLE 9-1. VDT 52S SWITCH CONFIGURATIONS

| | | | | | | | | | | |
|-------|------------------|-----|-----|-----|-----------------|---|---|---|---|-------------------|
| | | 0 | 1 | 2 | 3 | 4 | 5 | 6 | 7 | |
| SWR 1 | | | | | | | | | | ON |
| | | | | | | | | | | OFF |
| | | 0 | 1 | 2 | 3 | 4 | 5 | 6 | 7 | |
| SWR 0 | | | | | | | | | | ON |
| | | | | | | | | | | OFF |
| SWR 1 | | | | | | | | | | ON |
| | | | | | | | | | | OFF |
| 7 | Block cursor | | | | | | | | | Underlined cursor |
| 6 | Test mode | | | | | | | | | Normal mode |
| 5 | Odd parity | | | | | | | | | Even parity |
| 4 | With parity | | | | | | | | | Without parity |
| SWR 1 | 0 | 1 | 2 | 3 | BAUD RATE (RCV) | | | | | |
| | ON | ON | ON | ON | 38,400 | | | | | |
| | OFF | ON | ON | ON | 19,200 | | | | | |
| | ON | OFF | ON | ON | 9,600 | | | | | |
| | OFF | OFF | ON | ON | 4,800 | | | | | |
| | ON | ON | OFF | ON | 2,400 | | | | | |
| | OFF | ON | OFF | ON | 1,200 | | | | | |
| | ON | OFF | OFF | ON | 600 | | | | | |
| | OFF | OFF | OFF | ON | 300 | | | | | |
| | ON | ON | ON | OFF | 150 | | | | | |
| SWR 0 | | | | | | | | | | ON |
| | | | | | | | | | | OFF |
| 7 | CR with LF | | | | | | | | | CR without LF |
| 6 | CREDIT arrows | | | | | | | | | VDT 52S arrows |
| 5 | CR, LF in col.80 | | | | | | | | | Stop in col.80 |
| 4 | Half Duplex | | | | | | | | | Full Duplex |
| SWR 0 | 0 | 1 | 2 | 3 | BAUD RATE (XMT) | | | | | |
| | ON | ON | ON | ON | 38,400 | | | | | |
| | OFF | ON | ON | ON | 19,200 | | | | | |
| | ON | OFF | ON | ON | 9,600 | | | | | |
| | OFF | OFF | ON | ON | 4,800 | | | | | |
| | ON | ON | OFF | ON | 2,400 | | | | | |
| | OFF | ON | OFF | ON | 1,200 | | | | | |
| | ON | OFF | OFF | ON | 600 | | | | | |
| | OFF | OFF | OFF | ON | 300 | | | | | |
| | ON | ON | ON | OFF | 150 | | | | | |

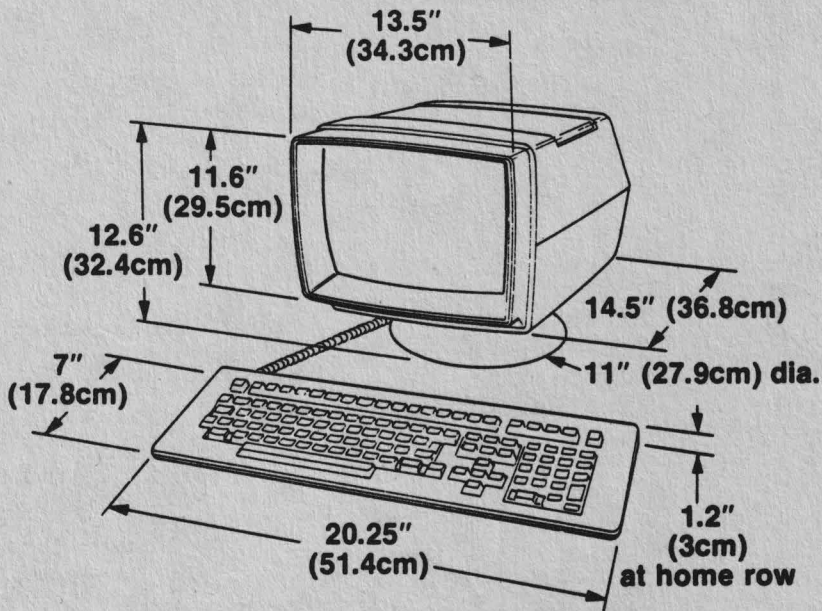

Figure 9-1. VDT 52S Dimensions

9.1.4 Monitor, Keyboard Adjustment

The VDT 52S monitor can be tilted and swiveled to position it in the optimum viewing angle for the operator. Adjustments can be made by pushing down the top of the monitor. "Clicks" heard, as the monitor is adjusted are from the positive detent mechanism, which holds the monitor securely in the desired position.

The keyboard may be tilted for maximum operator comfort. Simply turn down the two feet located under the rear of the keyboard housing, if desired.

9.2 INTERFACE INFORMATION

The VDT 52S may be cabled directly to a local computer, serial printer (or other auxiliary device), or it may be connected via telephone data lines to a remotely located computer. Remote computer connections require the use of a modem or data set. Figure 9-3, page 57 shows a typical VDT 52S application.

Figure 9-2, page 55 shows the rear panel locations of the interface connectors. Figure 9-4, page 58 shows the logic associated with these interfaces.

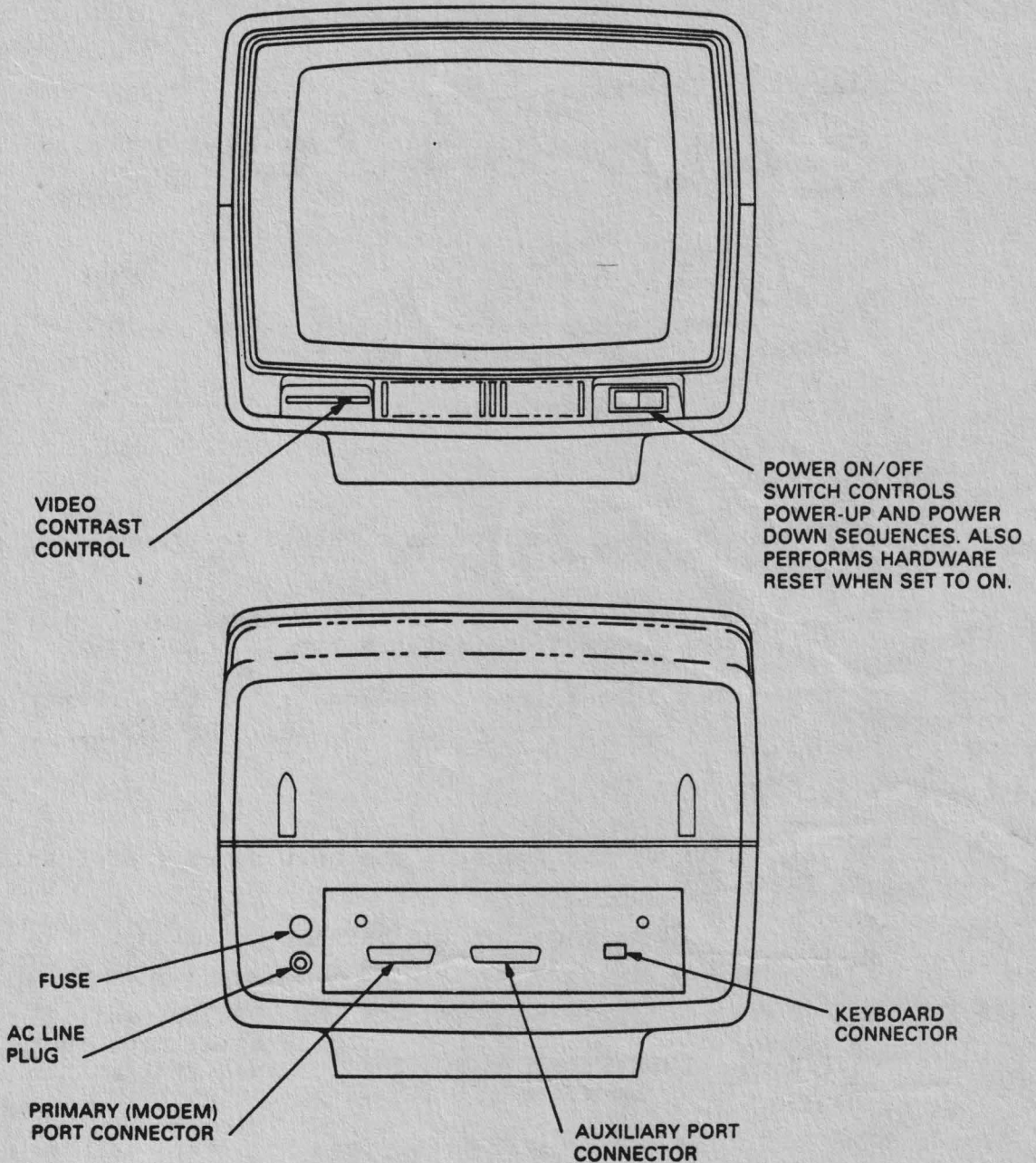

Figure 9-2. VDT 52S Controls and Connectors

9.2.1 RS-232C Interface

The Primary (Modem) Port RS-232C Interface provides the signals and levels associated with RS-232C, allowing direct connection to a computer or modem. The maximum permissible cable length is 50 feet for RS-232C applications.

9.2.2 Auxiliary Port Interface

The Auxiliary Port is used for connecting a serial printer or other device to the terminal using RS-232C signal levels and X-ON, X-OFF protocol.

N O T E

The peripheral device that is attached to the Auxiliary port must operate at the same baud rate as the communication line.

9.3 INSTALLING THE VDT 52S

1. Check the ON/OFF switch on front of unit. Refer to Figure 9-2, page 55 to ensure that is set to OFF.
2. Connect the data interface cable(s) to the terminal using the appropriate interface information (paragraph 9.2, page 54).
3. Plug the power cord into a grounded AC outlet of the proper voltage.

9.4 POWER TURN-ON

1. Set the ON/OFF switch on the front of the unit to ON (refer to Figure 9-2, page 55).
2. Wait approximately 20 seconds for the unit to warm up. The cursor should appear in the HOME position.
3. If the cursor does not appear, turn off the VDT 52S, wait 15 seconds and apply power again. If the cursor still does not appear, check the CONTRAST control, then contact your authorized I.C.E. FELIX service representative.
4. Adjust CONTRAST control (Figure 9-2, page 55) for desired display brightness.

N O T E

To avoid damage to the CRT screen when the terminal is to remain ON but unchanged for extended periods of time, reduce the screen brightness using the CONTRAST control on front of unit.

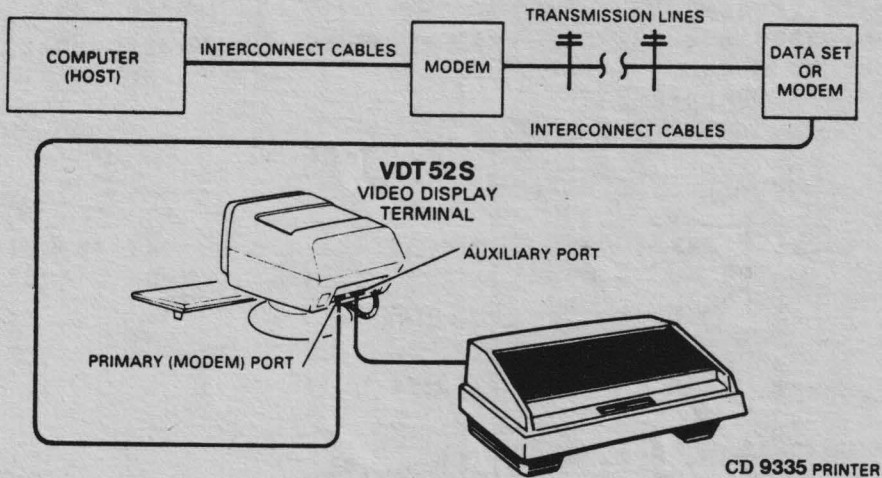

Figure 9-3. Typical VDT 52S Applications

9.5 SCREEN SAVER

To prevent damage to the CRT screen, a Screen Saver feature is enabled as the factory default condition. If the screen display is not changed for approximately 5 minutes, the display disappears from the screen and is retained in memory. Depressing any key (or data received) will return the display to the screen.

9.6 POWER TURN-OFF

If the unit is displaying information which must be retained, be sure to transmit this information to the host immediately. This is necessary, as the display is cleared when power is removed from the unit. An alternative is to send the information to a printer prior to turning the unit OFF.

9.7 CARE OF THE VDT 52S

9.7.1 Cleaning

At periodic intervals, clean the exterior housing and lightly dust the unit using a soft brush or damp lint-free cloth or paper towels. Do not use petroleum base cleaners, such as lighter fluid, as this could be harmful to the housing. Remove smudges from the CRT exterior screen and housing with conventional spray cleaners or alcohol.

9.7.2 Inspection

The characters on the screen should remain sharp, clear, and intense for the life of the terminal. If this should vary, your authorized I.C.E. FELIX service representative can quickly make any required mechanical and electrical adjustments.

MODEM CONECTOR / RS 232C

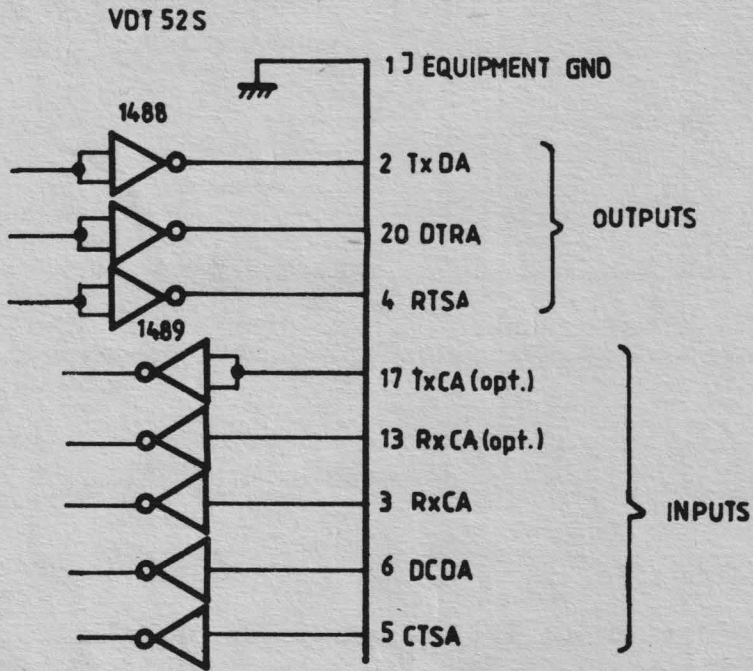

AUXILIARY PORT / RS 232C

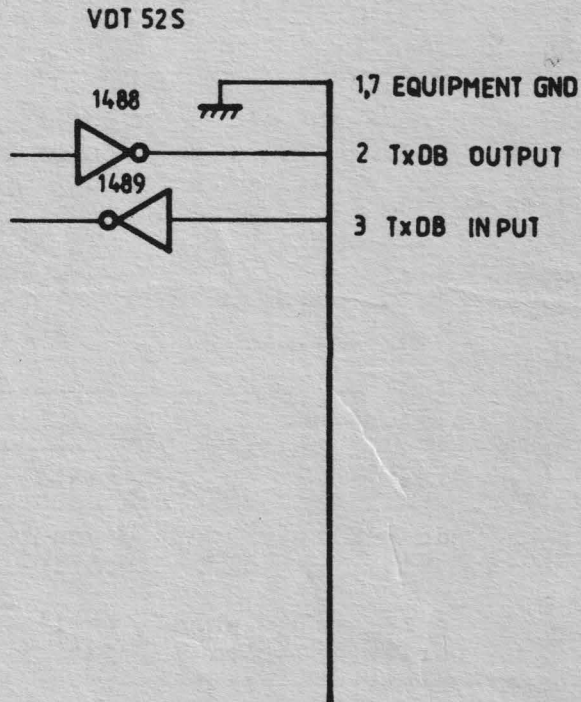

Figure 9-4. Modem Connector and Auxiliary Port

CHANGE INFORMATION

CONFIGURATION SWITCHES AND THE SETUP MODE

1. CONFIGURATION SWITCHES

The VDT52S includes 16 configuration switches used for individually turning the built-in terminal features on or off. It is important to note that these switches are inspected to select the built-in features only when the terminal is powered on. The user may very easily change the current selected features during subsequent operation, making use of a special mode of operation called SETUP mode.

The 16 configuration switches are divided into 2 groups of 8 switches each: the option selection group and the baud rate selection group.

The significance of the option selection switches is summarized in the following table:

| Option switch number | Selected feature | Value when switch in OFF | Value when switch is ON |
|----------------------|-------------------|---------------------------------------------------------------------|----------------------------------------------------------------------|
| 1 | page length | 24 lines per page | 25 lines per page |
| 2 | line width | 80 characters per line | 85 characters per line |
| 3 | scroll mode | jump scroll | smooth scroll |
| 4 | alpha cursor type | blinking block | blinking underline |
| 5 | auto line feed | disabled | enabled |
| 6 | wraparound | enabled | disabled |
| 7 | parity | disabled | enabled |
| 8 | parity sense | odd parity when parity enabled parity bit 0 when parity disabled | even parity when parity enabled parity bit 1 when parity disabled |

The significance of the above mentioned features will be explained in greater detail in the next sections.

The baud rate selection switches determine the communication speed of the VDT52S terminal, when it is turned on:

| Selected feature | Baud rate switch status | | | | | | | | Speed value (baud) |
|------------------|-------------------------|-----|-----|-----|----|----|----|----|--------------------|
| | 1 | 2 | 3 | 4 | 5 | 6 | 7 | 8 | |
| Transmit speed | ON | ON | ON | ON | | | | | 38400 |
| | OFF | ON | ON | ON | | | | | 19200 |
| | ON | OFF | ON | ON | | | | | 9600 |
| | OFF | OFF | ON | ON | | | | | 4800 |
| | ON | ON | OFF | ON | | | | | 2400 |
| | OFF | ON | OFF | ON | | | | | 1200 |
| | ON | OFF | OFF | ON | | | | | 600 |
| | OFF | OFF | OFF | ON | | | | | 300 |
| Receive speed | ON | ON | ON | OFF | ON | ON | ON | ON | 38400 |
| | OFF | ON | ON | OFF | ON | ON | ON | ON | 19200 |
| | ON | OFF | ON | OFF | ON | ON | ON | ON | 9600 |
| | OFF | OFF | ON | OFF | ON | ON | ON | ON | 4800 |
| | ON | ON | OFF | OFF | ON | ON | ON | ON | 2400 |
| | OFF | ON | OFF | OFF | ON | ON | ON | ON | 1200 |
| | ON | OFF | OFF | OFF | ON | ON | ON | ON | 600 |
| | OFF | OFF | OFF | OFF | ON | ON | ON | ON | 300 |
| | ON | ON | ON | OFF | ON | ON | ON | ON | 150 |

NOTE 1. When the upper or lower nibbles in the baud rate selection switches are set otherwise than listed above, the transmit or receive speed of the terminal are initialized with the default value of 150 baud.

NOTE 2. The transmit speed switches 1, 2, 3 and 4 also determine the communication speed between the VDT52S terminal and the local printer. Unlike the transmit speed to the host computer, the communication speed with the local printer may not be changed in SETUP mode.

2. THE SETUP MODE

The SETUP mode allows the VDT52S terminal to be very easily tailored to its operating environment. Changing any or all the SETUP features is a simple operation to be executed by the operator from the keyboard. It consists of the following steps:

a) Enter SETUP mode by pressing the SETUP STATUS key in the upper left corner of the keyboard. The SETUP mode may be entered from any of the 6 operating modes (alphanumeric or graphic), although the SETUP features concern mainly the alphanumeric functioning. The current cursor disappears and at the bottom of the screen (the 25th line) the SETUP status information is displayed in reverse video. The SETUP status line contains the names and the current settings for the 12 SETUP features of the terminal, as in the following example:

LG:24 WD:80 SCR:J CRS:B ALF:N WRP:Y PAR:Y PRS:E

CLK:Y MBL:N TS: 9600 RS: 9600

There are two possible settings for each of the first ten SETUP features and nine possible settings for the last two features (transmit and receive speeds). The actual meaning of each SETUP feature will be explained later in detail.

b) Change a feature setting by pressing the corresponding functional key F1, F2, ... , F11 or F12 on the upper side of the keyboard. The number of the dedicated softkey accompanies the feature name in the SETUP status line (F10, F11 and F12 keys are displayed as 0, 1 and 2). Each time the key is pressed the feature will change, generally to the opposite state. For example, if you press the F4 key, you will change the alpha cursor appearance, from blinking block (CRS:B in the SETUP line) to blinking underline (CRS:U) and viceversa.

c) Repeat step b) for all the features you want to change. The changes may be performed in any order.

d) Exit SETUP mode by pressing again the SETUP STATUS key. The SETUP status line disappears and the terminal resumes normal operation. The modified feature settings remain active until one of the following events occurs:

- the SETUP mode is entered again by the operator;
- some of the SETUP features may also be changed by certain specific commands from the computer, without entering the SETUP mode (see next section);
- the terminal is turned off. When turning it on again, the VDT52S will "read" the SETUP features settings from the configuration switches, as described earlier.

NOTE 1.

Normal operations on the screen are suspended during SETUP mode, but the communication with the computer is not interrupted. The VDT52S terminal, while in SETUP mode, will deposit the data received from the computer in its own input buffer. If the input buffer becomes nearly full, the VDT52S will automatically send an XOFF code (13H) to notify the computer to stop transmission. After the SETUP mode is exited, the terminal will resume normal operation and will deplete the input buffer, executing the commands stored therein. When 4 characters remain in the buffer, the terminal will transmit an XON code (11H) to signal the host that it may resume transmission.

NOTE 2.

When returning from SETUP mode to alpha operating mode, the alpha cursor is generally placed in the previous current alpha position. Two exceptions apply to this rule:

- if the cursor was previously placed in the 25th line and the page length was changed from 25 to 24 lines during the SETUP mode, then the alpha cursor is repositioned in the 24th line (same column):

- if the cursor was previously placed in one of the columns 81, 82, 83, 84 or 85, and the line width was changed from 85 to 80 characters during the SETUP mode, then the alpha cursor is repositioned in the 80th column (same line).

NOTE 3.

When exiting SETUP mode, the contents of the 25th line depend on the VDT52S terminal version:

- in the minimum version (6K PROM, 1K RAM), the 25th line is blanked, so its contents from the previous operating mode are lost;

- in the complete version (8K PROM, 64K RAM), the VDT52S restores the 25th line to its previous contents, alphanumeric or graphic.

3. THE SETUP FEATURES

3.1 Page length

The VDT52S, while in alphanumeric mode, is capable of displaying either 24 (LG:24 in the SETUP line) or 25 (LG:25 in the SETUP line) alphanumeric lines per page.

The page length may be changed locally, pressing the F1 key in SETUP mode. If the cursor was previously placed in the 25th line and the page length is changed from 25 to 24 lines during the SETUP mode, then the alpha cursor is repositioned in the 24th line (same column).

The page length may also be changed (from 24 lines per page to 25 lines and viceversa) by the computer command ESC,'8' = 1BH,38H. In this case, a screen erasure operation follows and the cursor is homed in the upper left corner.

3.2 Line width

The VDT52S, while in alphanumeric mode, is capable of displaying either 80 (WD:80 in the SETUP line) or 85 (WD:85 in the SETUP line) characters per line. The first choice is the usual one and is suited for most of the alphanumeric applications. The 85 characters per line feature allows the entire screen width to be used for alpha purposes; this may be necessary in certain mixed (alpha and graphic) applications.

The line width may be changed locally, pressing the F2 key in SETUP mode. If the cursor was previously placed in one of the columns 81, 82, 83, 84 or 85, and the line width is changed from 85 to 80 characters during the SETUP mode, then the alpha cursor is repositioned in the 80th column (same line).

The line width may also be changed (from 80 characters per line to 85 and viceversa) by the computer command ESC,'9' = 1BH,39H. In this case, a screen erasure operation follows and the cursor is homed in the upper left corner.

3.3 Scroll

Scrolling is the upward or downward movement of existing lines on the screen to make room for new lines at the bottom or top of the screen. It can be performed in two ways: jump scroll or smooth scroll. In jump scroll mode (designated as SCR:J in the SETUP status line), new lines appear on the screen as fast as the computer sends them to the terminal. At the higher baud rates, the data is very difficult to read due to the rapid movement of the lines. In smooth scroll mode (SCR:S in the SETUP line), a limit is placed on the speed at which new lines of data may be displayed on the screen. The movement of lines occurs at a smooth steady rate, allowing the data to be read as it appears on the screen.

The scrolling mode may be changed locally, pressing the F3 key in SETUP mode.

3.4 Cursor

The VDT52S offers a choice of two cursor representations to indicate the alphanumeric "current position", or where the next character will be placed on the screen. The alpha cursor may be displayed as either a blinking block (CRS:B in the SETUP line) or a blinking underline (CRS:U in the SETUP line).

The cursor type may be changed locally, pressing the F4 key in SETUP mode.

3.5 Auto Line Feed

This feature enables the RETURN key on the terminal to function like the RETURN key on an electric typewriter. When the auto line feed feature is enabled (ALF:Y in the SETUP line), pressing the RETURN key generates the carriage return (CR=ODH) and line feed (LF = OAH) codes. When a line feed code is received, the code is interpreted as a carriage return and line feed.

When the auto line feed feature is disabled (ALF:N in the SETUP line), the RETURN key generates only the CR code; an LF code causes the terminal to perform a line feed only.

The auto line feed facility may be changed locally, pressing the F5 key in SETUP mode.

3.6 Wraparound

When this feature is enabled (WRP:Y in the SETUP line), the 81st or 86th character (depending upon the line size selected) inserted on a line is automatically placed in the first character position of the next line. If the wraparound feature is not enabled (WRP:N in the SETUP line), the 81st or 86th character and all following characters would be overwritten into the last character position of the current line.

The wraparound facility may be changed locally, pressing the F6 key in SETUP mode.

3.7 Parity

Parity, when enabled (PAR:Y in the SETUP line) checks for correct data transmission. If a transmission error occurs, the VDT52S can detect it and indicate its presence by placing a special character () on the screen in place of the character with the error, and also generating an audible alarm. The parity sense feature determines if the parity check is even or odd. The terminal generates the appropriate parity bit for the characters sent, according to the parity sense setting.

When parity is disabled (PAR:N in the SETUP line), the parity bit is ignored for all the characters received, and is forced to 0 or 1 for all the characters sent, according to the parity sense setting.

The parity check may be enabled or disabled locally, pressing the F7 key in SETUP mode.

3.8 Parity sense

The parity sense feature defines which of the two methods of parity checking, odd (PRS:O in the SETUP line) or even (PRS:E in the SETUP line), is being used by the VDT52S. If the parity feature is on, the terminal's parity sense must be matched to the parity the computer is sending. If a parity incompatibility occurs, the received character is rejected and is replaced on the screen with the special error character ().

If the parity feature is off, the parity sense feature (PRS:O or PRS:1 in the SETUP line) determines the value of the forced parity bit the terminal appends to any character it sends.

The parity sense may be changed locally, pressing the F8 key in SETUP mode.

3.9 Keyclick

The keyclick is a tone which is generated every time a code transmitting key is pressed. The keyclick feature may be turned on (CLK:Y in the SETUP line) or off (CLK:N) to suit the operator needs. However, research and experience has shown that an operator is more accurate when there is an audible feedback from the keyboard.

Unlike the other SETUP features, the keyclick is not switch selectable. It is enabled (CLK:Y) when the terminal is powered on, and may be changed only in SETUP mode.

The keyclick option may be enabled or disabled locally, pressing the F9 key in SETUP mode.

3.10 Margin bell

The margin bell feature is much the same as the bell in a typewriter. If this feature is enabled (MBL:Y in the SETUP line) and the cursor is eight characters from the end of the current line while typing, the VDT52S sounds a tone to alert the operator.

Unlike the other SETUP features, the margin bell is not switch selectable. It is disabled (MBL:N in the SETUP line) when the terminal is powered on, and may be changed only in SETUP mode.

The margin bell facility may be enabled or disabled locally, pressing the F10 key in SETUP mode.

3.11 Transmit speed

Transmit speed must be set to match the host computer receive speed. The VDT52S is capable of transmitting at any one of the following transmit speeds: 38400, 19200, 9600, 4800, 2400, 1200, 600, 300 and 150 baud.

As described earlier, when it is turned on, the VDT52S "reads" the transmit speed from the configuration switches. The current transmit speed may be visualized in the SETUP status line, after the prefix TS: . If necessary, the operator may change the transmit speed, making use of the F11 functional key in SETUP mode. The repeated pressing of the F11 key causes the terminal to step through all the 9 possible settings of the transmit speed, in circular descending order; the user must choose the value that match the computer receive speed.

3.12 Receive speed

The receive speed must be set to match the host computer transmit speed. The VDT52S is capable of receiving at any one of the following speeds: 38400, 19200, 9600, 4800, 2400, 1200, 600, 300 and 150 baud.

As described earlier, when it is turned on, the VDT52S "reads" the receive speed from the configuration switches. The current receive speed may be visualized in the SETUP status line, after the prefix RS: . If necessary, the operator may change the receive speed, making use of the F12 functional key in SETUP mode. The repeated pressing of the F12 key causes the terminal to step through all the 9 possible settings of the receive speed, in circular descending order; the user must choose the value that match the computer transmit speed.

The receive speed is independent of the transmit speed; the terminal may receive data at one speed and transmit data at a different speed.

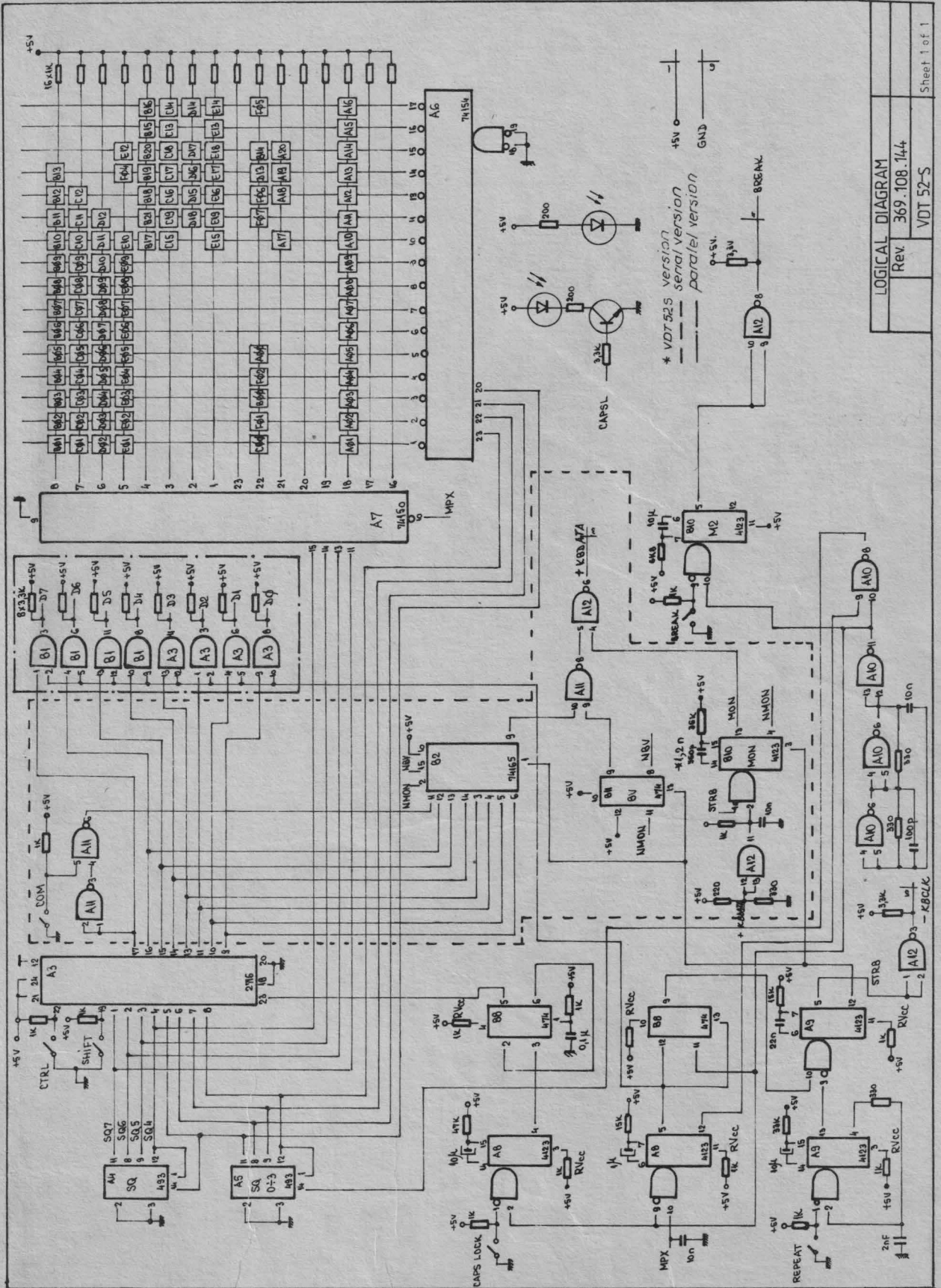

LOGICAL DIAGRAM
 Rev. 369.108.144
 VDT 52-S

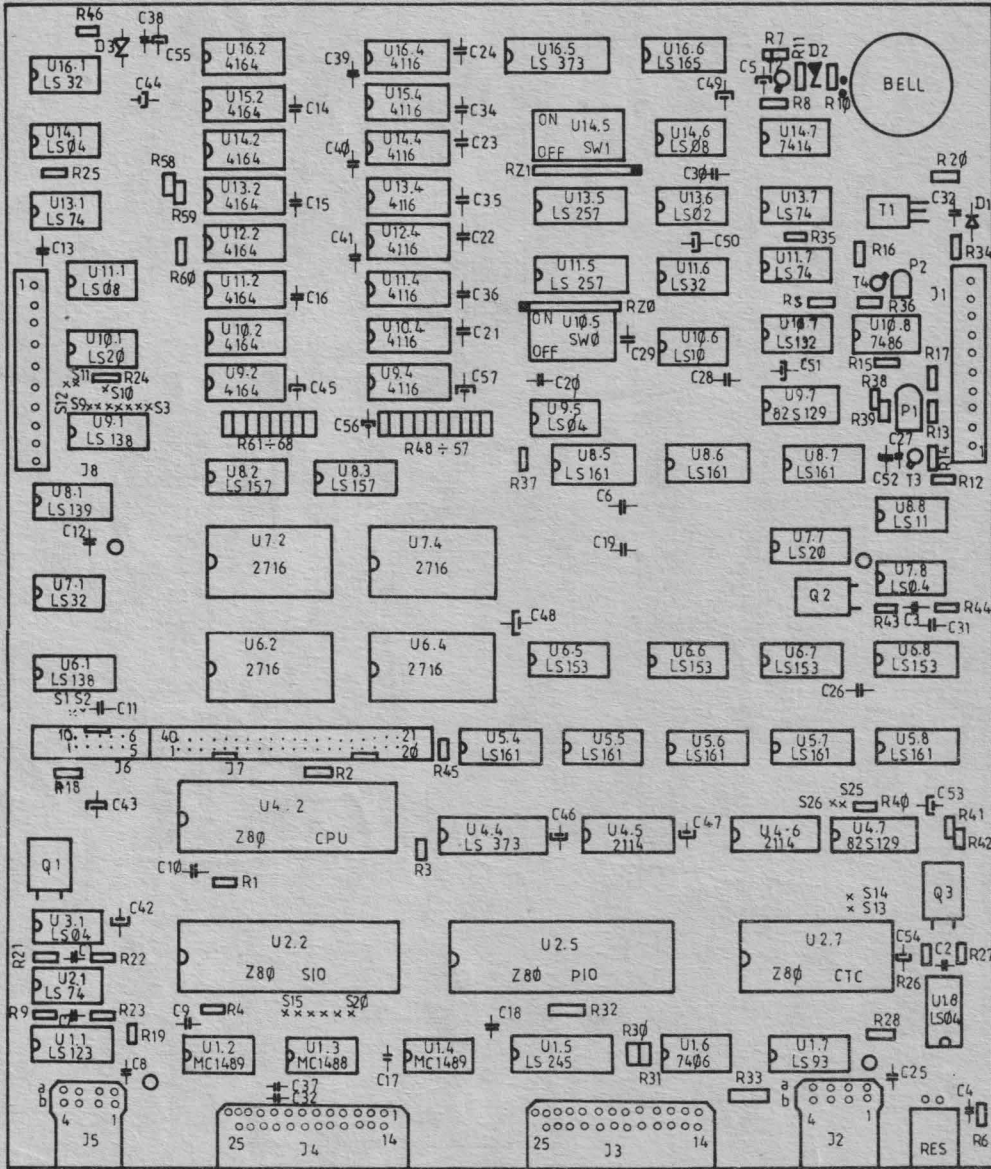

MODIFICATIONS FOR CONNECTING ROBOTRON 1157 (IF SP)
 PRINTER AS HARD-COPY FOR VDT 52-S

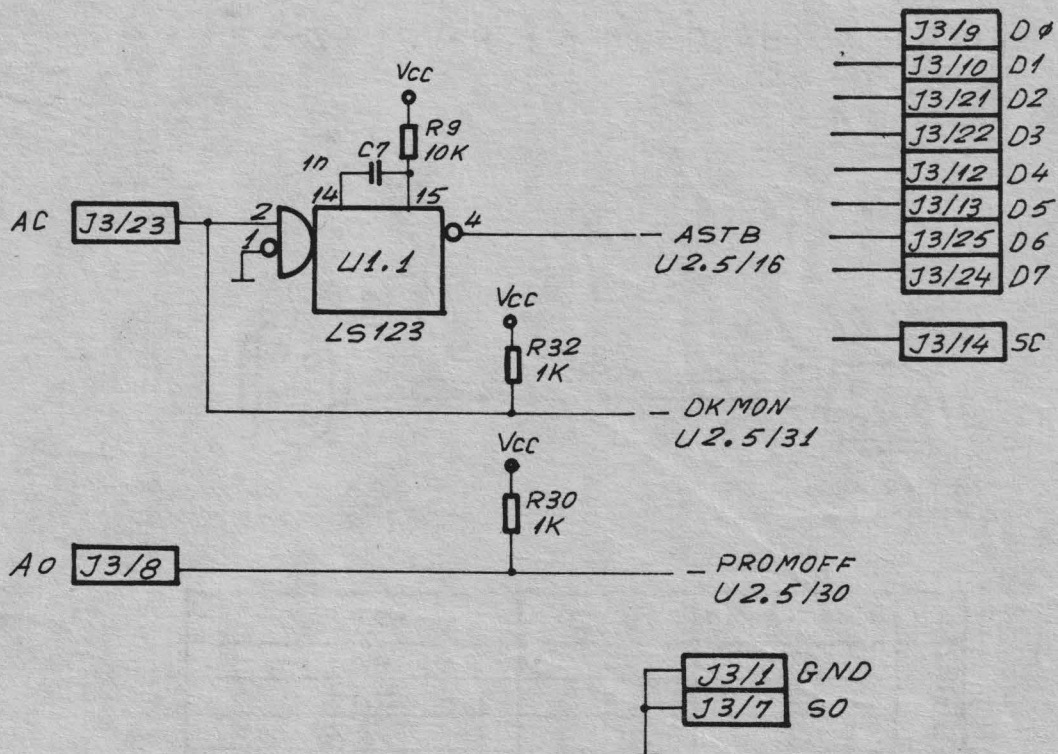

Interruptions:

- U2.5/30 wire (solder side)
- U2.5/16 wire (solder side)
- U1.1/2 wire (solder side)
- U1.1/1 wire (component side, under U1.1)
- U1.1/12 wire (component side, under U1.1)

BREAK jumper (U2.5/16 - U2.2/29)

Components added:

- U1.1 (LS123) and U1.5 (LS245)
- R9 (10K Ω , RPM 3050, 5%)
- C7 (1nF, MC 3223, 10%, 50V)

Jumpers:

- J318 - U2.5/30
- J3/23 - U2.5/31 - U1.1/2
- U1.1/1 - U1.1/8
- U1.1/4 - U2.5/16
- U9.1/6 - U10.1/2
- 521 - 522

| | | |
|----------|---------------|--------------|
| VDT 52-S | | |
| | HARD-COPY | |
| | ROBOTRON 1157 | Sheet 1 of 2 |

CABLE FOR CONNECTING ROBOTRON 1157 (IFSP)

PRINTER AS HARD-COPY FOR VDT 52-S

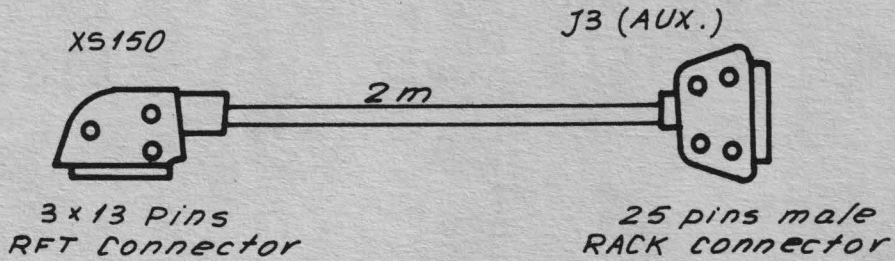

| No. | From xs150 | To J3 | Signal |
|-----|------------|-------|----------|
| 1 | B2 | 14 | SC |
| 2 | B3 | 23 | AC |
| 3 | B4 | 1 | S0 (GND) |
| 4 | B5 | 9 | D0 |
| 5 | B6 | 10 | D1 |
| 6 | B7 | 21 | D2 |
| 7 | B8 | 22 | D3 |
| 8 | B9 | 12 | D4 |
| 9 | B10 | 13 | D5 |
| 10 | B11 | 25 | D6 |
| 11 | B12 | 24 | D7 |
| 12 | B13 | 8 | A0 |
| 13 | A1 | 1 | GND |
| 14 | C1 | 7 | GND |

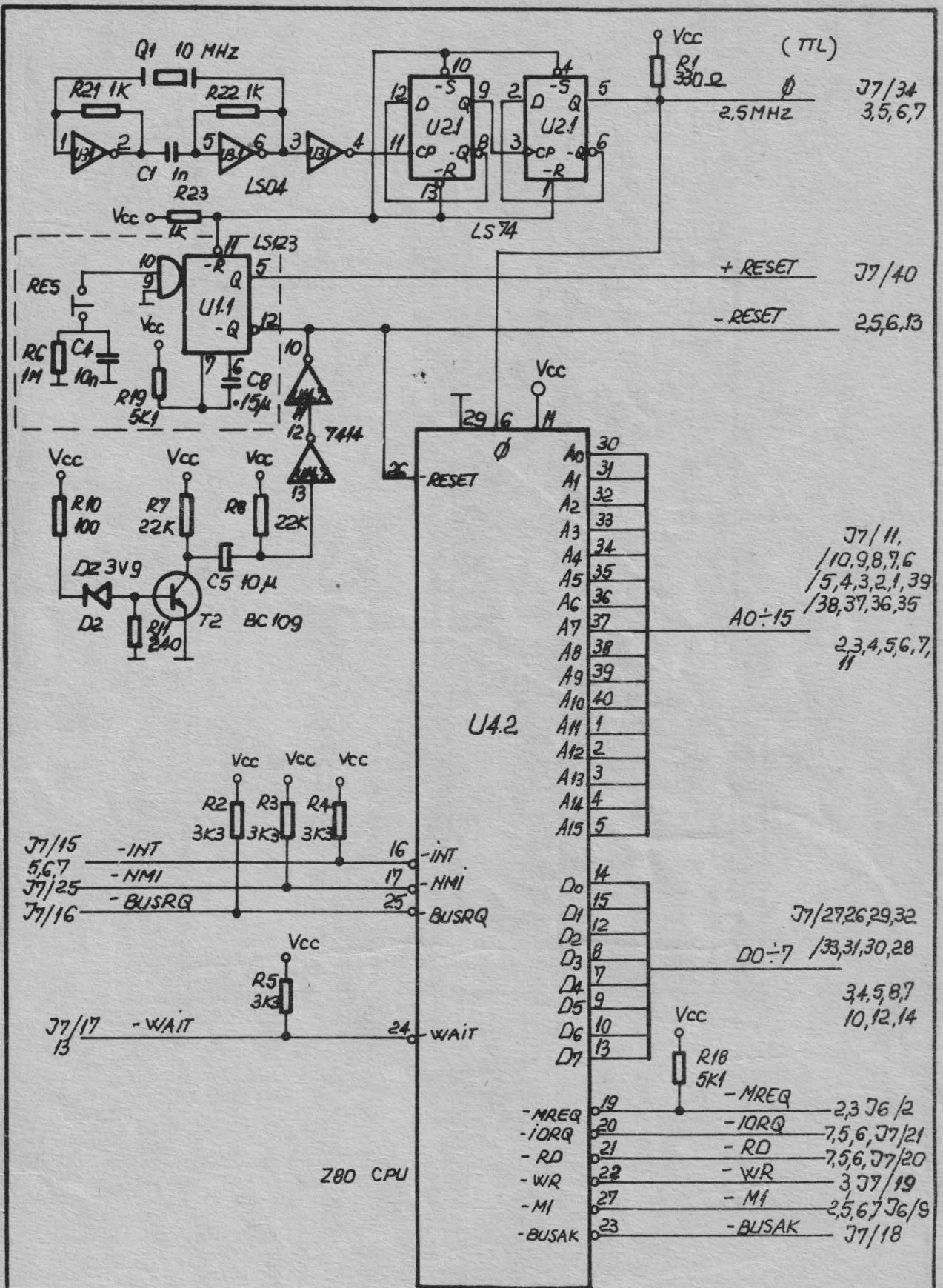

| | | |
|---------------------|-----|---------------|
| VDT-52-S MAIN BOARD | | URC 85.01 |
| Rev. | CPU | |
| | | Sheet 1 of 16 |

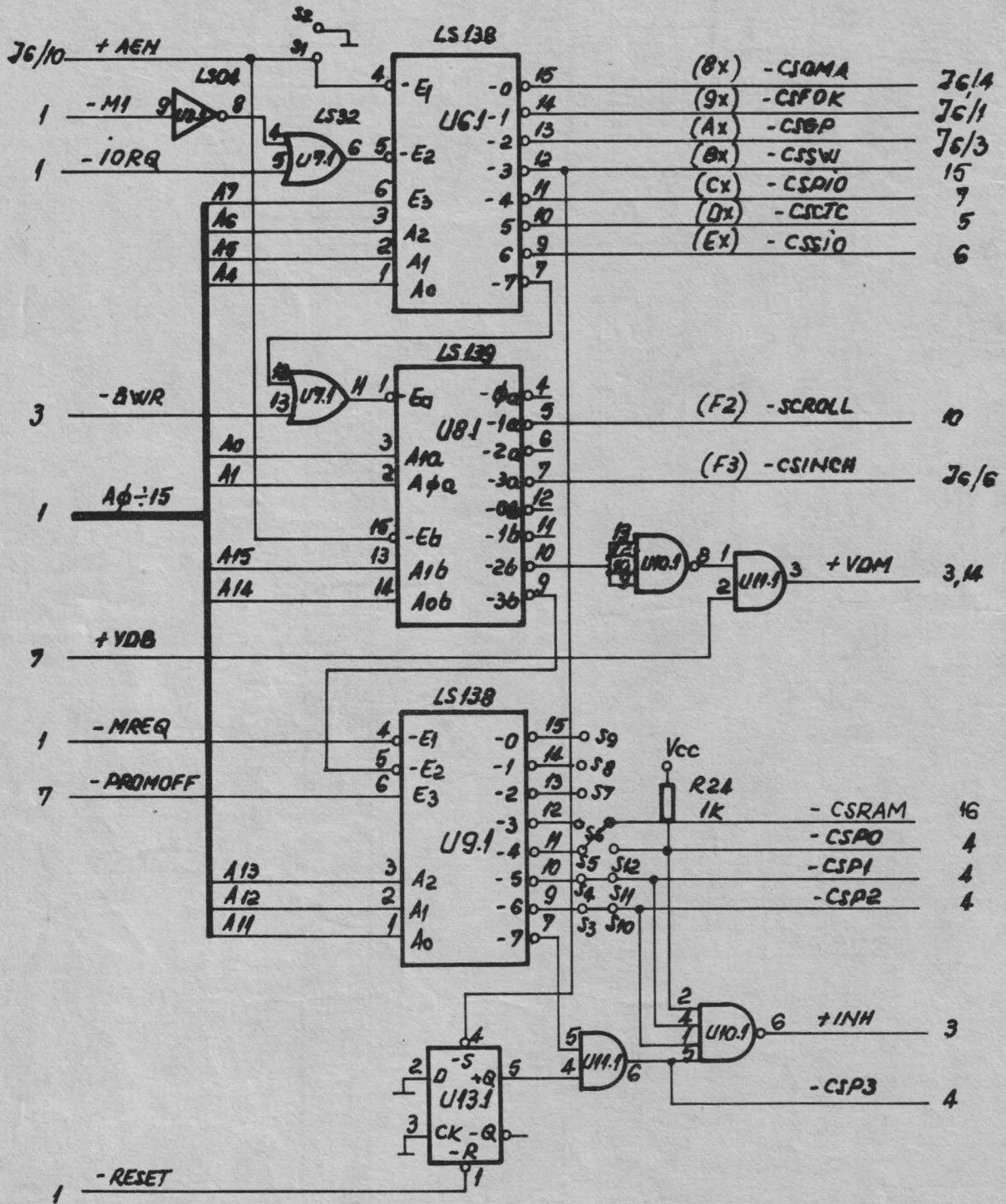

| | | |
|---------------------|------------|---------------|
| VDT 52-S MAIN BOARD | | URC 85.01 |
| Rev. | i/o DECOER | |
| | | Sheet 2 of 16 |

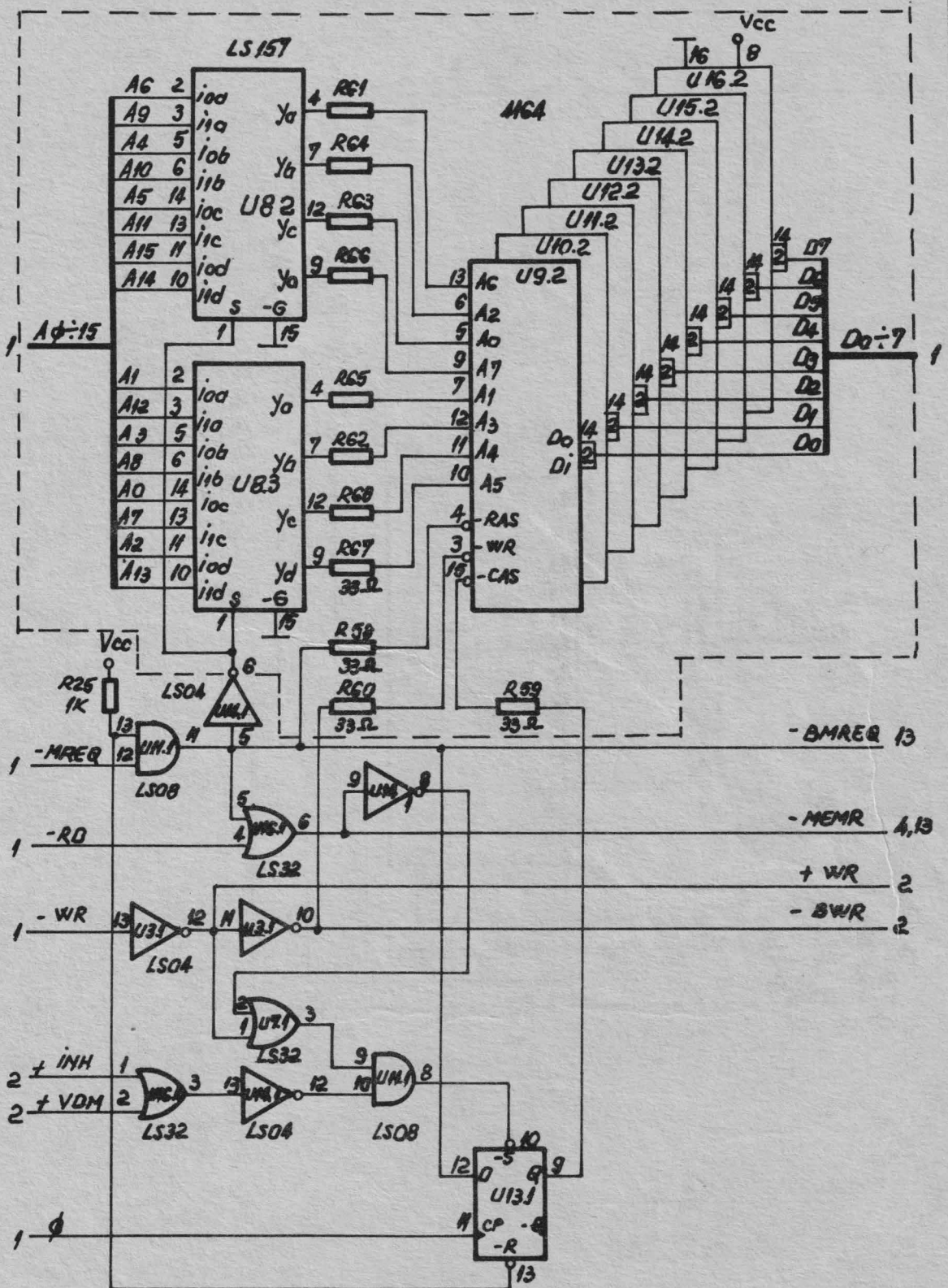

| | | |
|---------------------|-----|---------------|
| VDT 52-S MAIN BOARD | | URC 85.01 |
| Rev | RAM | |
| | | Sheet 3 of 16 |

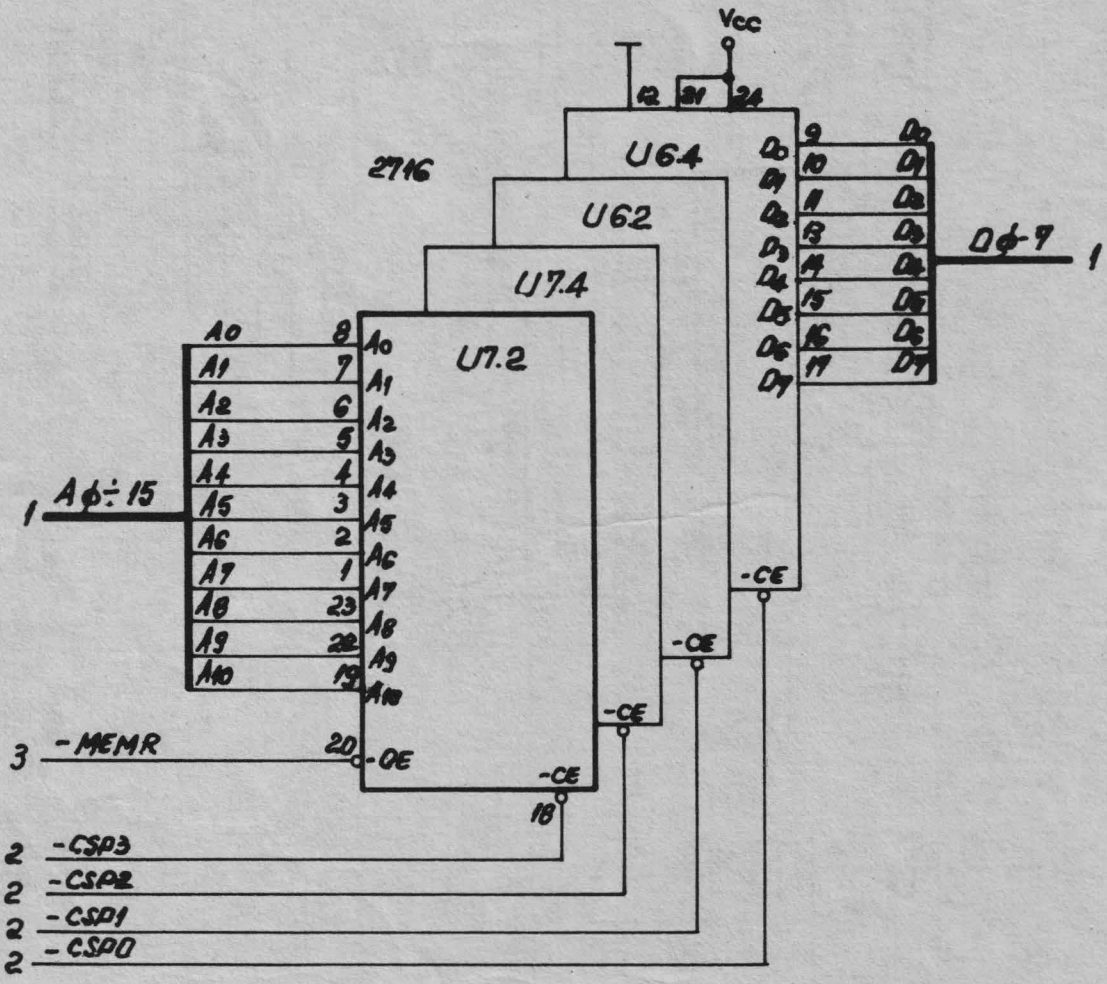

| | | |
|---------------------|-------|---------------|
| VDT 52-S MAIN BOARD | | URC 85.01 |
| Rev | EPROM | |
| | | Sheet 4 of 16 |

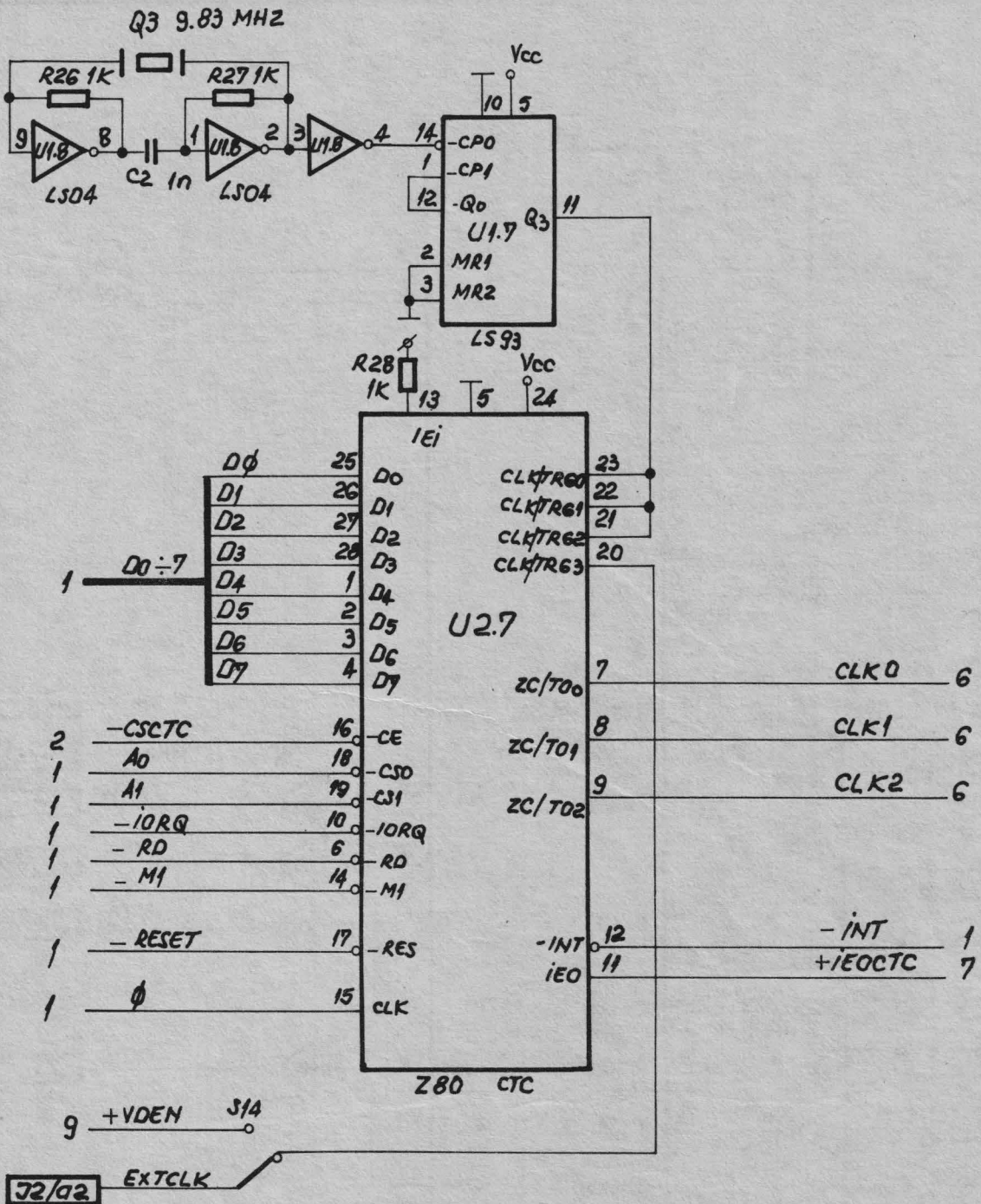

| | | |
|---------------------|-------|---------------|
| VDT 52-S MAIN BOARD | | URC 85.01 |
| Rev. | TIMER | |
| | | Sheet 5 of 16 |

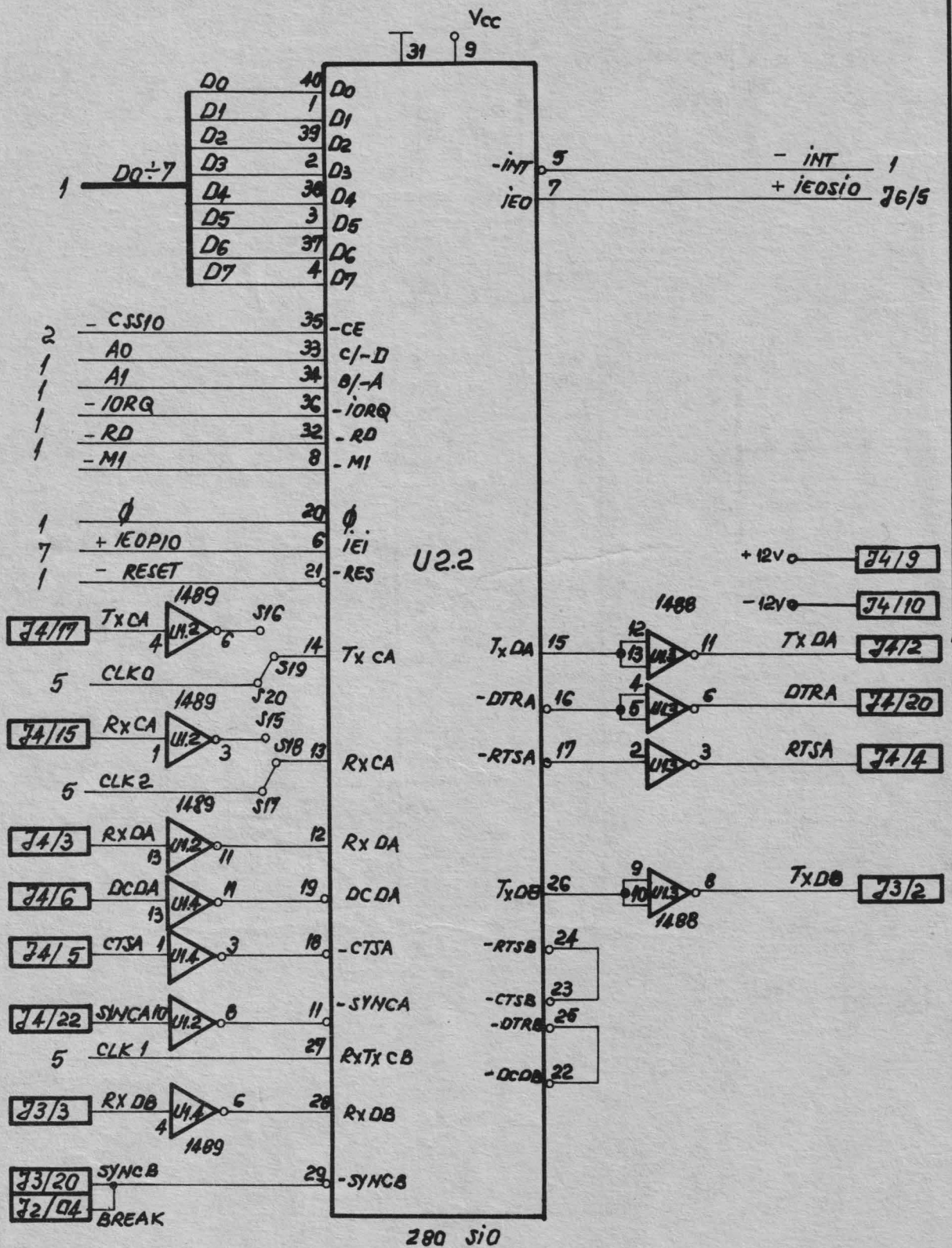

| | | |
|---------------------|------------|---------------|
| VDT 52-S MAIN BOARD | | URC 85.01 |
| Rev. | SERIAL I/O | |
| | | Sheet 6 of 16 |

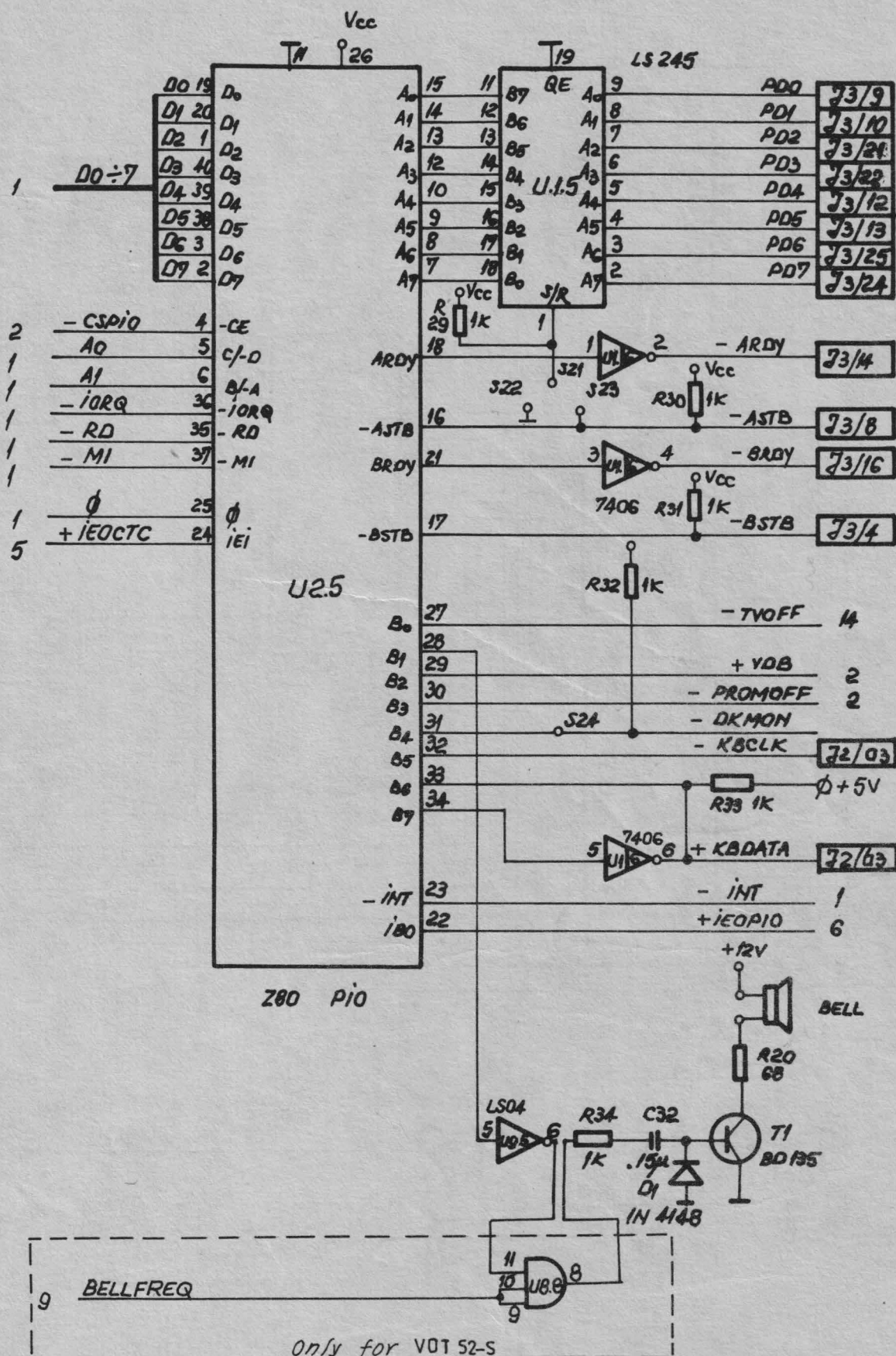

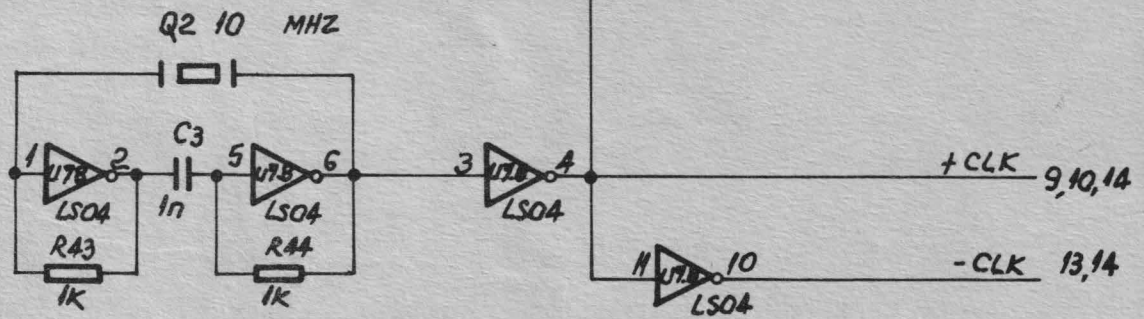
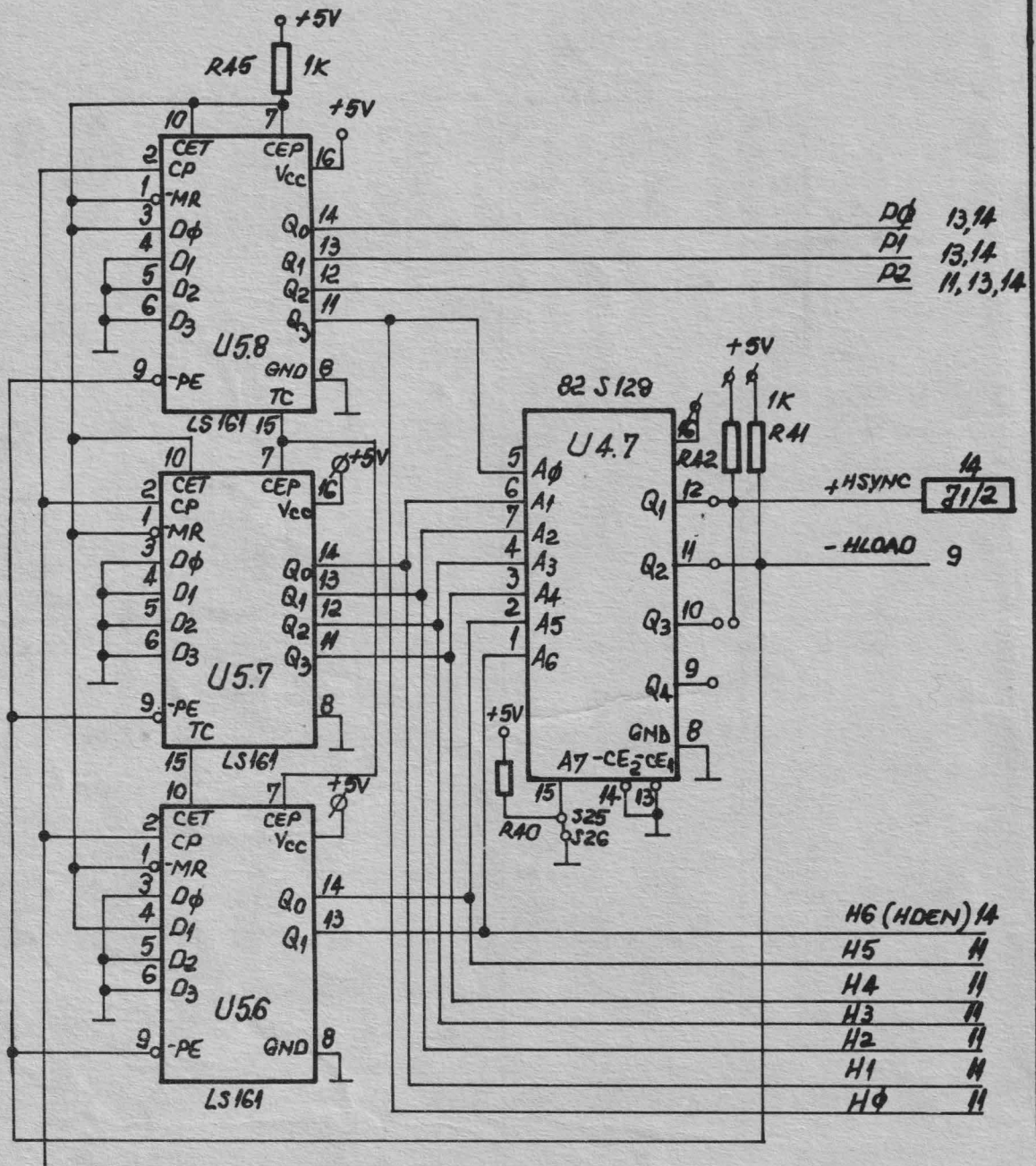

| | | |
|---------------------|-----------------|---------------|
| VDT 52-S MAIN BOARD | | URC 85.01 |
| Rev | HORIZONTAL SYNC | |
| | | Sheet 8 of 16 |

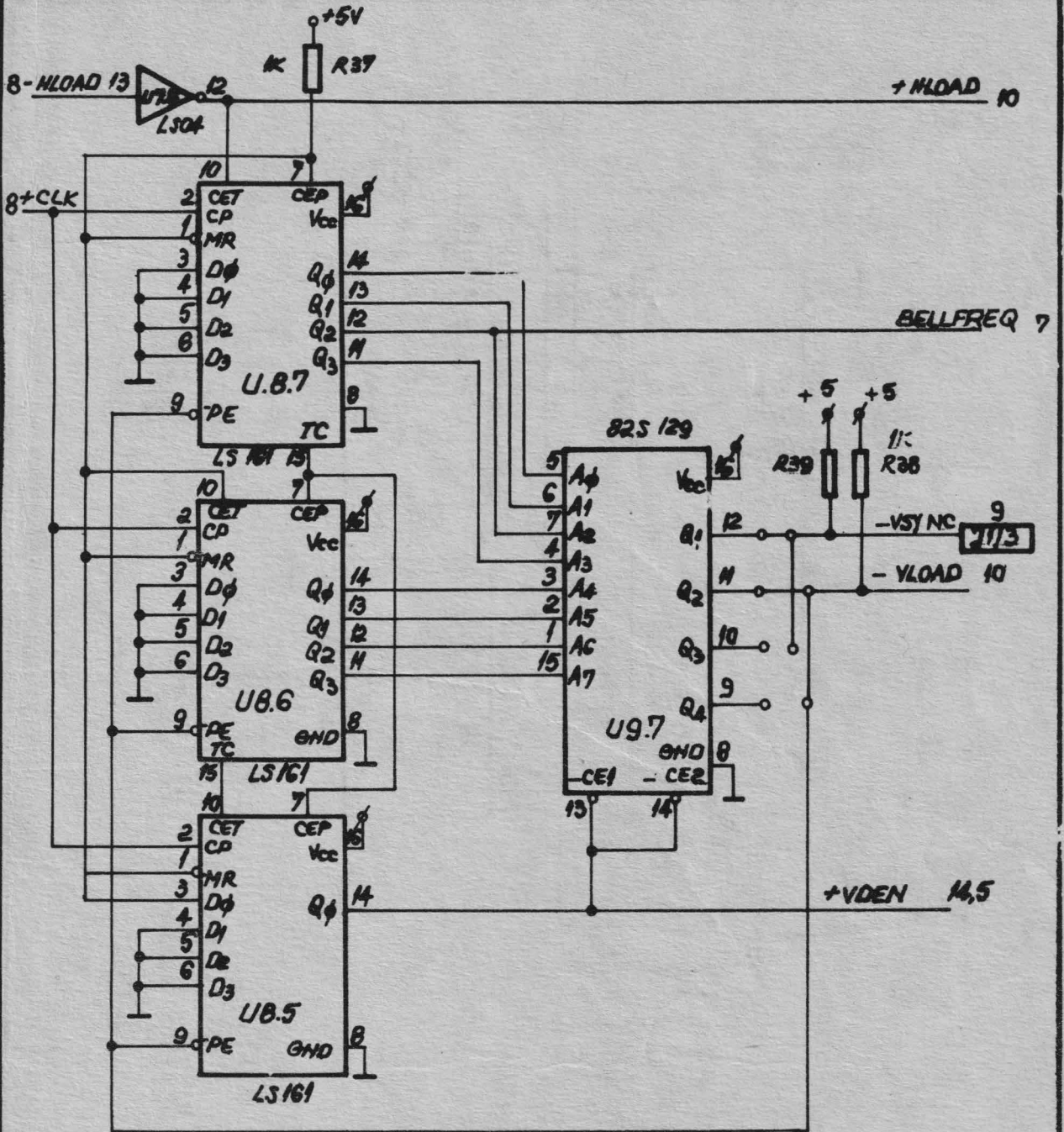

| | | |
|---------------------|---------------|---------------|
| VDT 52-S MAIN BOARD | | URC 85.01 |
| Rev. | VERTICAL SYNC | |
| | | Sheet 9 of 16 |

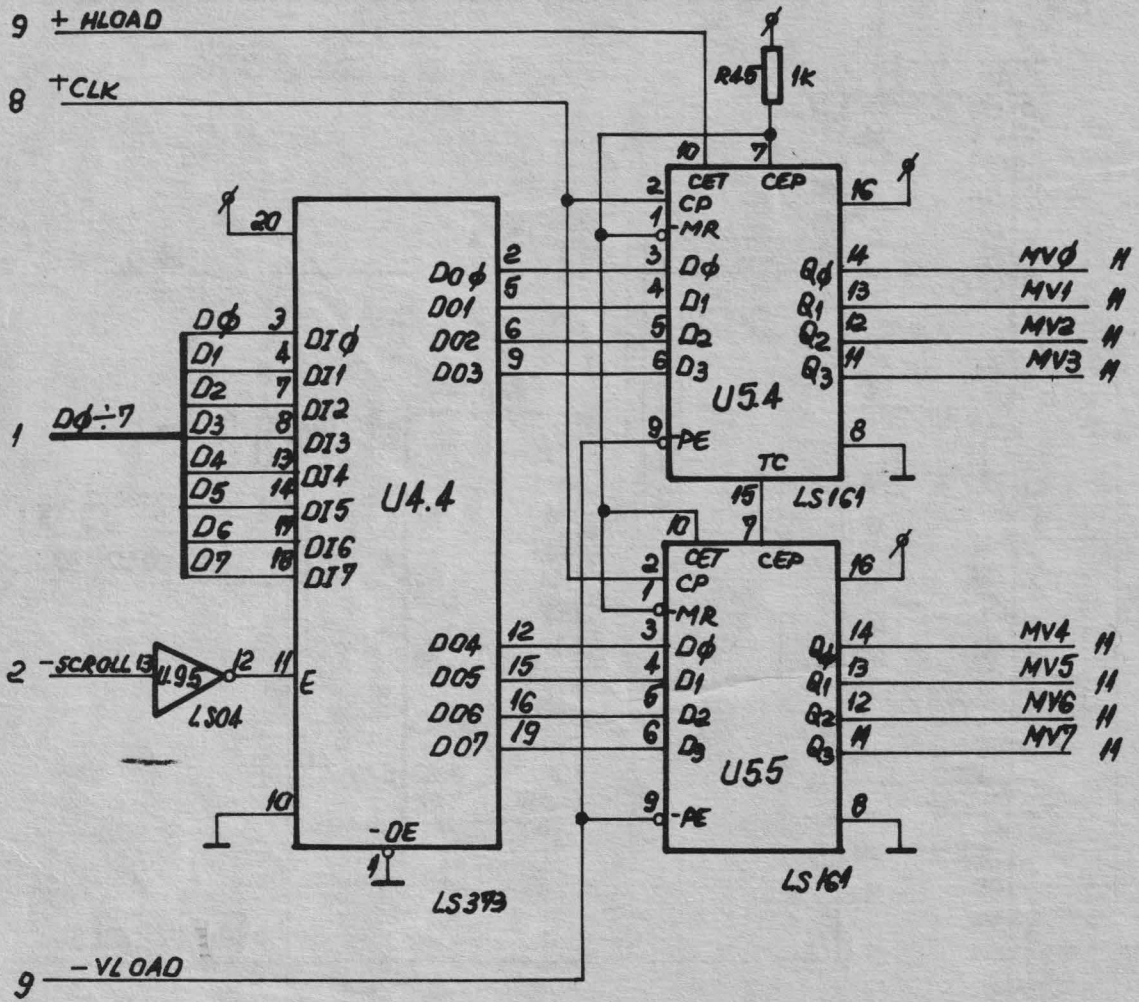

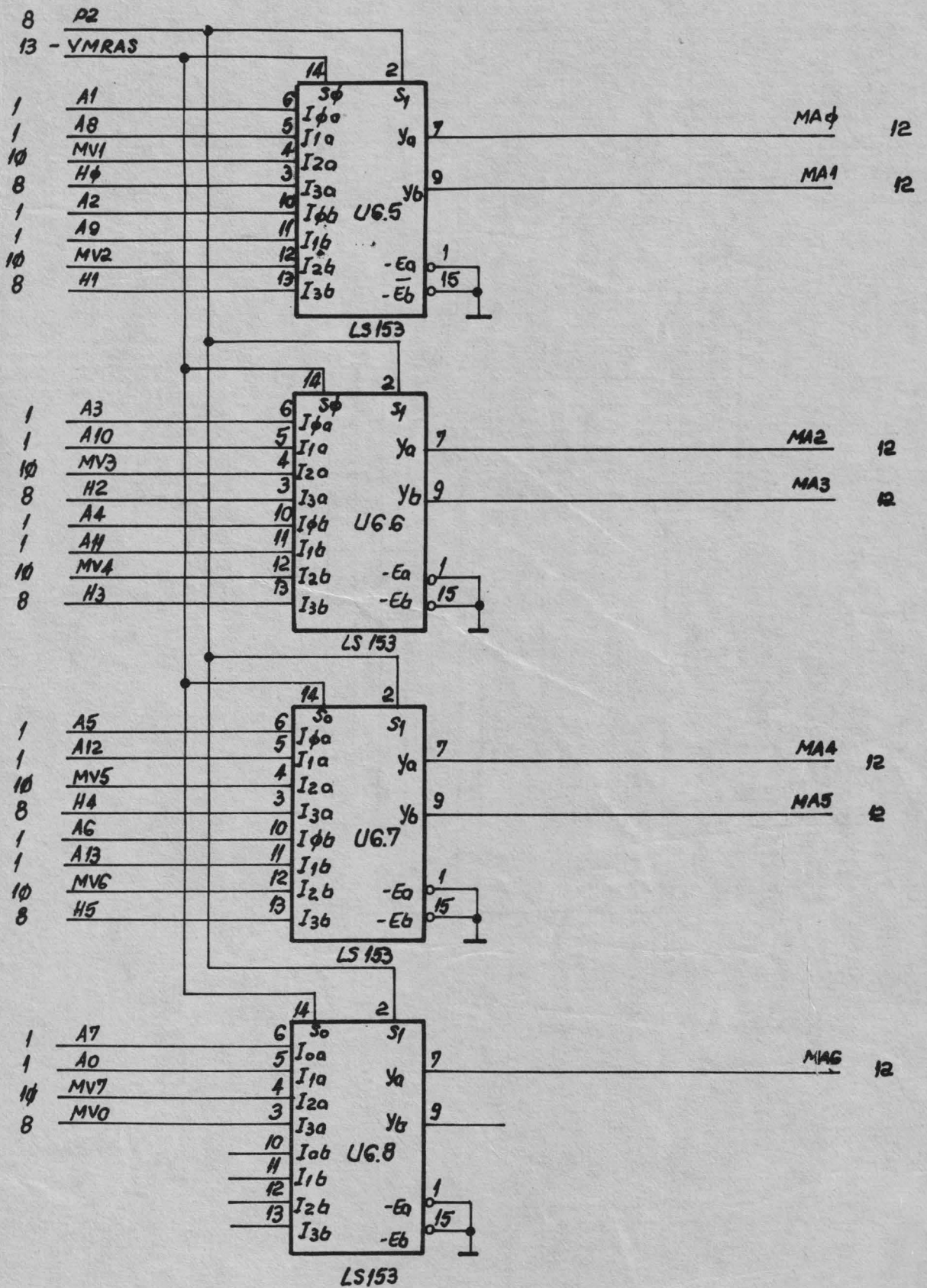

| | | |
|---------------------|---------------|----------------|
| VDT 52-S MAIN BOARD | | URC: 85.01 |
| Rev. | VIDEO RAM MUX | |
| | | Sheet 11 of 16 |

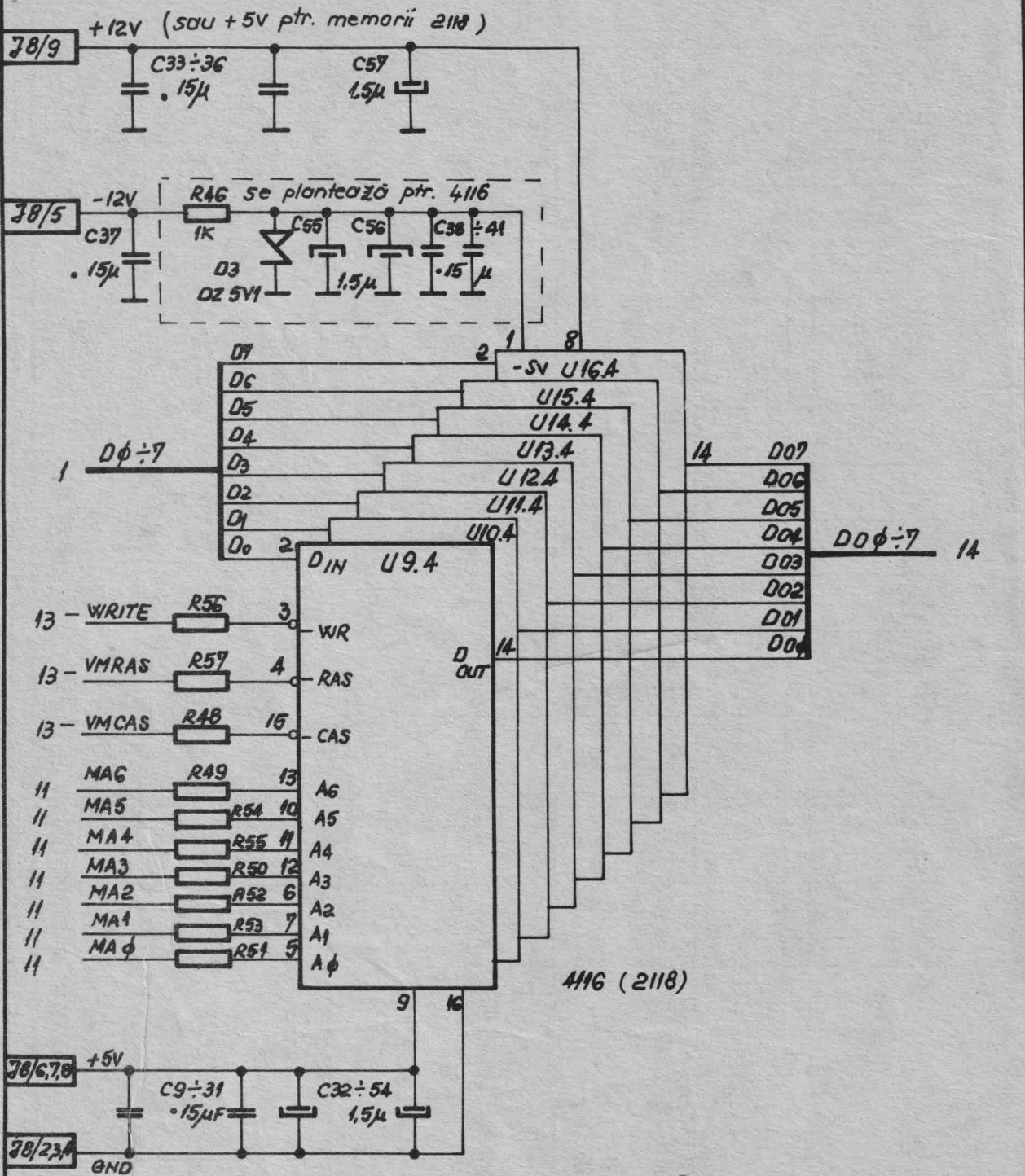

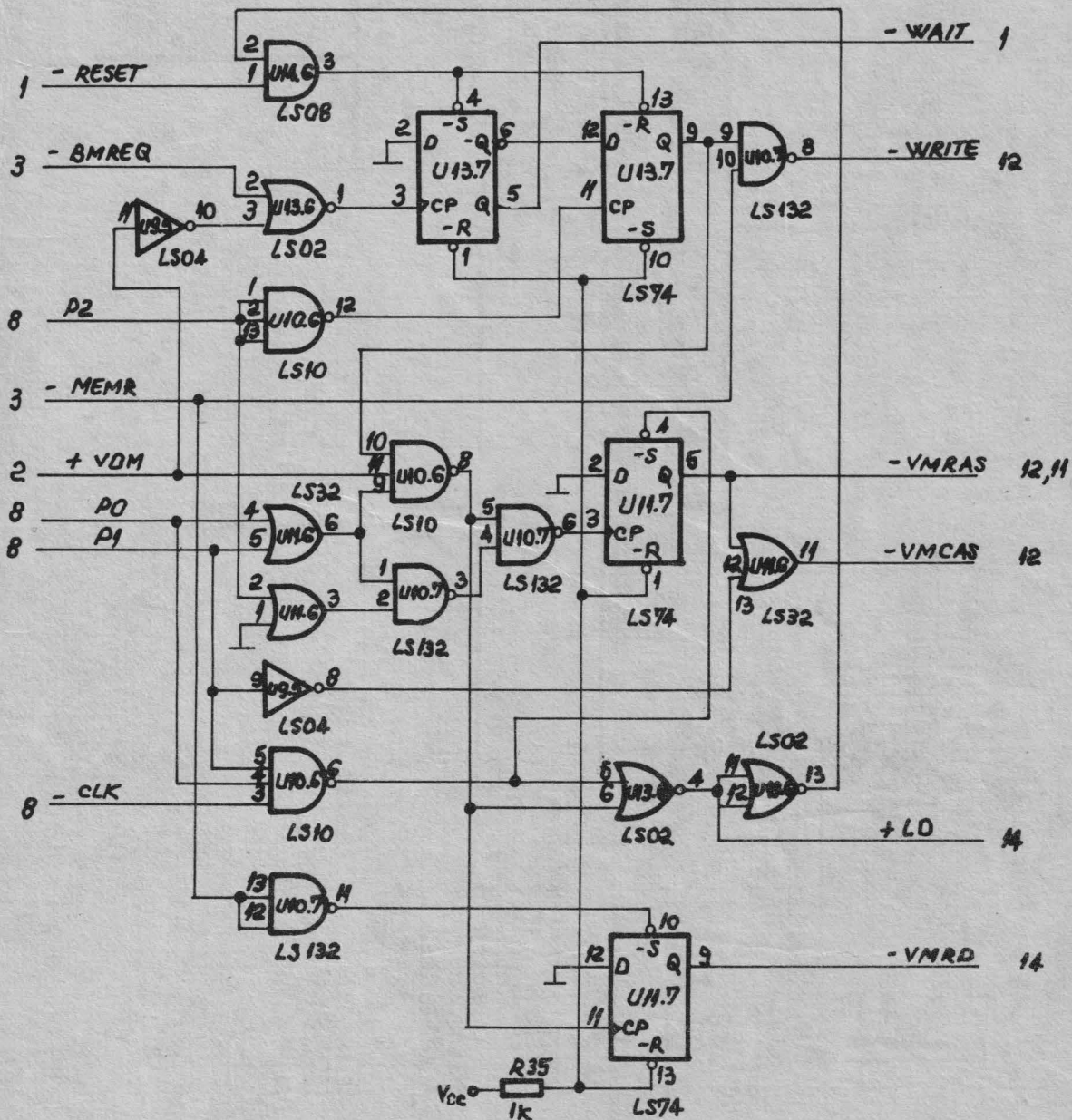

| | | |
|---------------------|---------------|----------------|
| VDT 52-S MAIN BOARD | | URC 85.01 |
| Rev. | VIDEO CONTROL | |
| | | Sheet 13 of 16 |

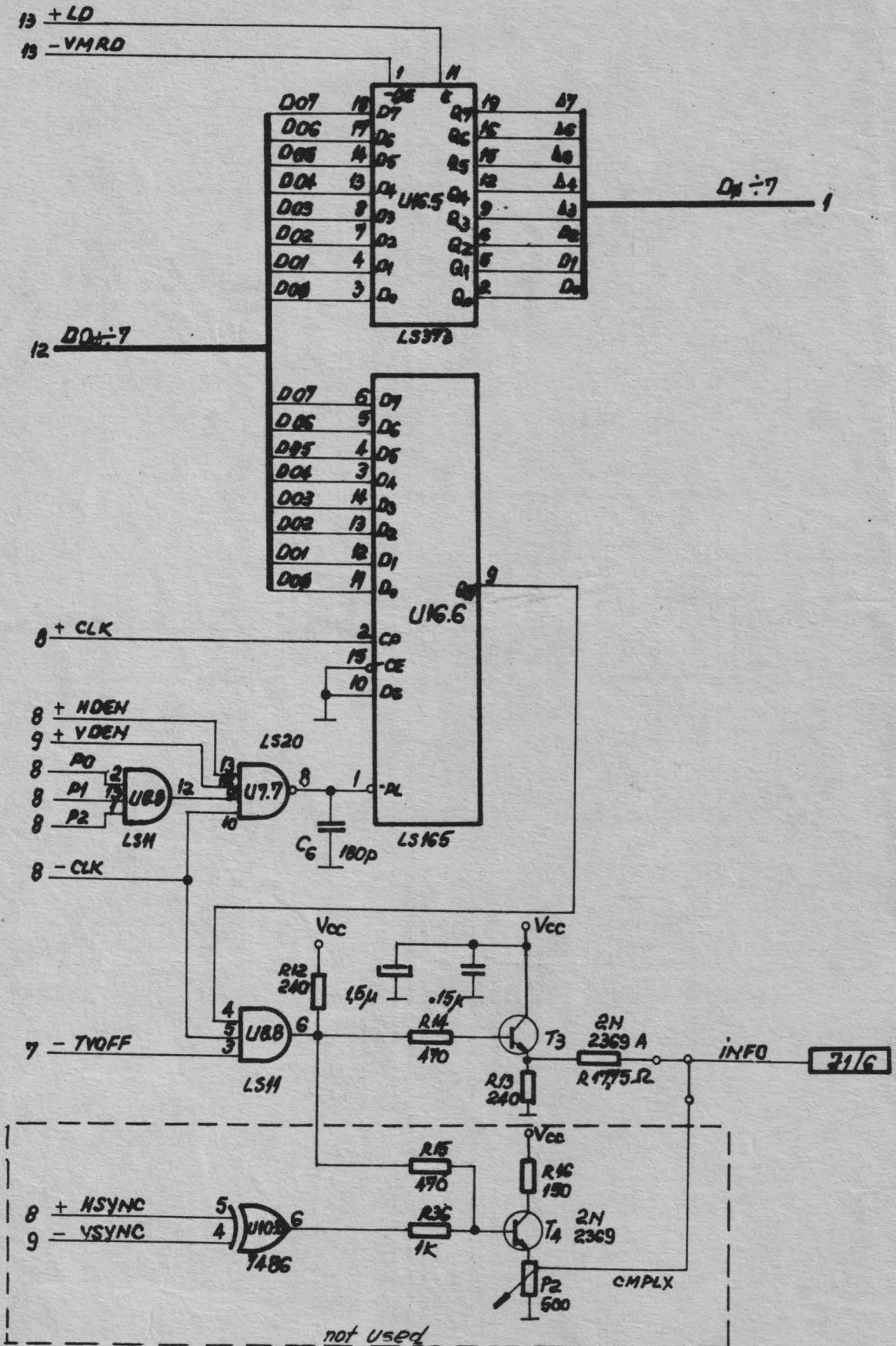

| | | |
|---------------------|-----------|----------------|
| VDT 52-S MAIN BOARD | | URC 85.01 |
| Rev | TV DRIVER | |
| | | Sheet 14 of 16 |

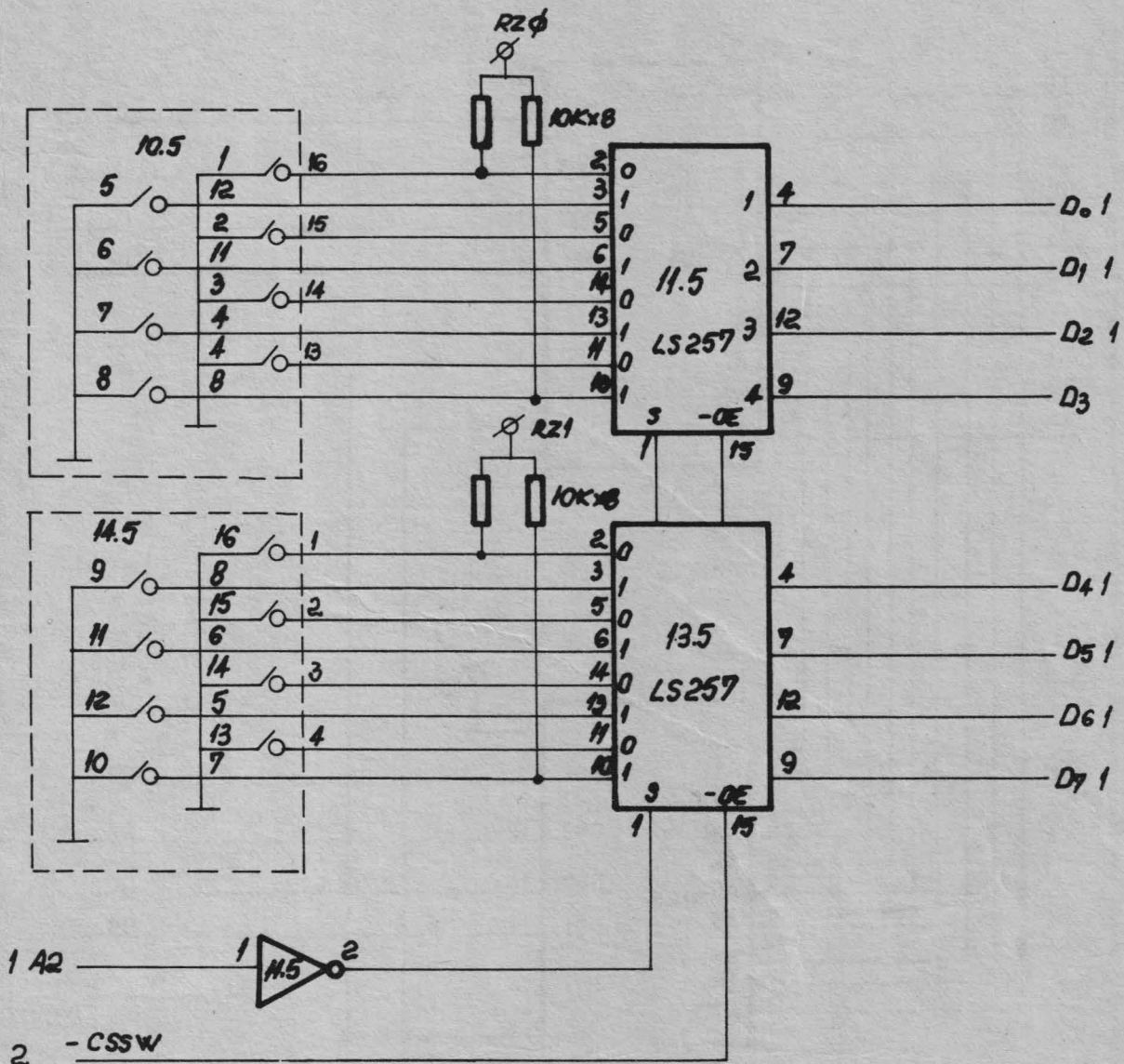

| | | |
|----------|----------|----------------|
| VDT 52-S | | URC 85.01 |
| Rev. | SWITCHES | |
| | | Sheet 15 of 16 |

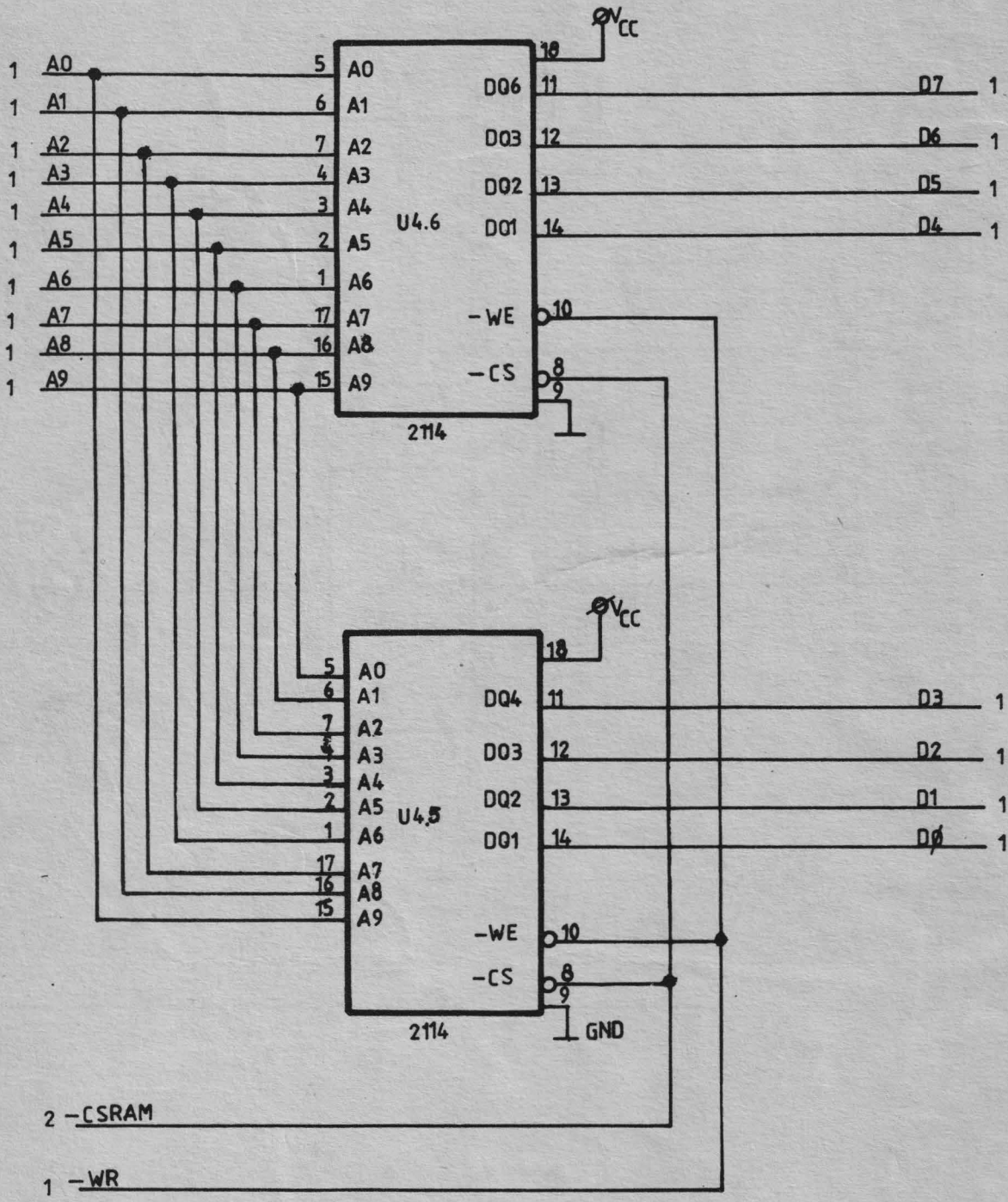

| | | |
|-----------------|------------|----------------|
| VDT 52-S | | |
| Rev. | STATIC RAM | |
| | | Sheet 16 of 16 |

CUT ALONG LINE

-----Address
-----Dept
-----Name

From:

FOLD

FOLD



**BUSINESS REPLY
MAIL**

AFFIX
POSTAGE
HERE

To:

INTREPRINDEREA DE CALCULATOARE ELECTRONICE

Documentation Departament

2 Ing. GEORGE CONSTANTINESCU st.

78009 - BUCURESTI 2

FOLD

FOLD

We will welcome your comments regarding any errors, discrepancies or omissions you may have discovered, or any suggestions for improving the overall manual. Your comments will be appreciated and should be a useful input at the next revision. Please include references to page number, line or column number, or figure number (as appropriate).

PRINTED IN I.C.E.

FOLD ALONG DOTTED LINES AND STAPLE

COMMENT SHEET

Manual title.....

.....

code.....rev.....

location.....



78009 2 G.Constantinescu St., BUCAREST 2, ROMANIA, Tx. 11626 felix r. ☎ 886030

Data Processing Systems

ELECTRONUM FOREIGN TRADE COMPANY
70201 33 Al.Sahia St. BUCHAREST 2 ROMANIA
PO.Box 1390 Tel. 90/138837 Telex 11547:11584
